



CAREER POINT

KVPY QUESTION PAPER-2020 (STREAM SB)

Part - I

One - Mark Questions

Date : 31 / 01 / 2021

MATHEMATICS

1. Consider the following statements :

I. $\lim_{n \rightarrow \infty} \frac{2^n + (-2)^n}{2^n}$ does not exist

II. $\lim_{n \rightarrow \infty} \frac{3^n + (-3)^n}{4^n}$ does not exist

Then

(A) I is true and II is false

(B) I is false and II is true

(C) I and II are true

(D) neither I nor II is true

Ans. [A]

Sol. I. $\lim_{n \rightarrow \infty} \left(\frac{2^n}{2^n} + \left(\frac{-2}{2} \right)^n \right)$

$= \lim_{n \rightarrow \infty} (1 + (-1)^n)$ does not exist

II. $\lim_{n \rightarrow \infty} \left(\left(\frac{3}{4} \right)^n + \left(\frac{-3}{4} \right)^n \right) = 0 + 0 = 0$

2. Consider a regular 10-gon with its vertices on the unit circle. With one vertex fixed, draw straight lines to the other 9 vertices. Call them L_1, L_2, \dots, L_9 and denote their lengths by l_1, l_2, \dots, l_9 respectively. Then the product l_1, l_2, \dots, l_9 is

(A) 10

(B) $10\sqrt{3}$

(C) $\frac{50}{\sqrt{3}}$

(D) 20

Ans. [A]

Sol.

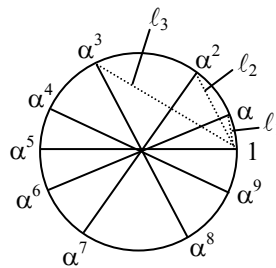

Let $\alpha = e^{i\left(\frac{2\pi}{10}\right)} = e^{i\frac{\pi}{5}}$

Now, $z^{10} - 1 = (z - 1)(z - \alpha) \dots (z - \alpha^9) \dots (1)$

$$\begin{aligned} \text{so, } \ell_1 \ell_2 \dots \ell_9 &= |1 - \alpha| |1 - \alpha^2| \dots |1 - \alpha^9| \\ &= |(1 - \alpha)(1 - \alpha^2) \dots (1 - \alpha^9)| \\ &= \left| \lim_{z \rightarrow 1} \frac{z^{10} - 1}{z - 1} \right| = 10 \end{aligned}$$

3. The value of the integral $\int_{-\pi/2}^{\pi/2} \frac{\sin^2 x}{1 + e^x} dx$ is

- (A) $\frac{\pi}{6}$ (B) $\frac{\pi}{4}$ (C) $\frac{\pi}{2}$ (D) $\frac{\pi^2}{2}$

Ans. [B]

Sol.
$$I = \int_0^{\pi/2} \left(\frac{\sin^2 x}{1 + e^x} + \frac{\sin^2 x}{1 + e^{-x}} \right) dx$$

$$= \int_0^{\pi/2} \sin^2 x dx = \frac{1}{2} \times \frac{\pi}{2} = \frac{\pi}{4}$$

4. Let R be the set of all real numbers and $f(x) = \sin^{10} x (\cos^8 x + \cos^4 x + \cos^2 x + 1)$ for $x \in R$. Let $S = \{\lambda \in R \mid \text{there exists a point } c \in (0, 2\pi) \text{ with } f'(c) = \lambda f(c)\}$. then

- (A) $S = R$ (B) $S = \{0\}$
 (C) $S = [0, 2\pi]$ (D) S is a finite set having more than one element

Ans. [A]

Sol. Let $g(x) = f(x) e^{-\lambda x}$, $x \in [0, 2\pi]$
 so, $g(0) = g(2\pi) = 0$ (as $f(0) = f(2\pi) = 0$)
 this, $\exists c \in (0, 2\pi)$
 such that $g'(c) = 0$
 $\Rightarrow f'(c) = \lambda f(c)$ $\forall \lambda \in R$
 $\Rightarrow S = R$

5. A person standing on the top of a building of height $60\sqrt{3}$ feet observed the top of a tower to lie at an elevation of 45° . That person descended to the bottom of the building and found that the top of the same tower is now at an angle of elevation of 60° . The height of the tower (in feet) is

- (A) 30 (B) $30(\sqrt{3} + 1)$ (C) $90(\sqrt{3} + 1)$ (D) $150(\sqrt{3} + 1)$

Ans. [C]

Sol.
$$\frac{60\sqrt{3} + d}{d} = \sqrt{3}$$

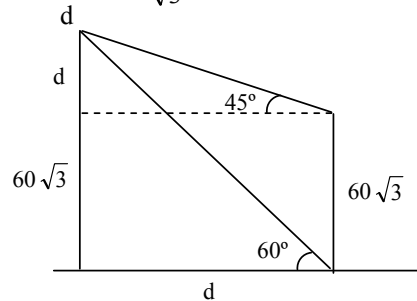

$$\begin{aligned} \Rightarrow d &= \frac{60\sqrt{3}}{\sqrt{3} - 1} \\ \Rightarrow h &= 60\sqrt{3} \left(1 + \frac{1}{\sqrt{3} - 1} \right) \\ &= \frac{60 \times 3}{\sqrt{3} - 1} = 90(\sqrt{3} + 1) \end{aligned}$$

6. Assume that $3.13 \leq \pi \leq 3.15$. The integer closest to the value of $\sin^{-1}(\sin 1 \cos 4 + \cos 1 \sin 4)$, where 1 and 4 appearing in sin and cos are given in radians, is :
 (A) -1 (B) 1 (C) 3 (D) 5

Ans. [A]

Sol. $\theta = \sin^{-1}(\sin 5)$

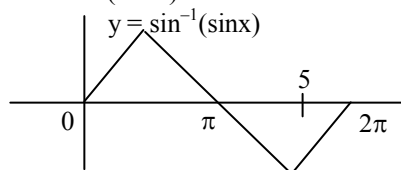

$$= -(2\pi - 5)$$

$$= 5 - 2\pi \approx -1.26 \quad (\text{as } \pi \approx 3.13)$$

7. The maximum value of the function $f(x) = e^x + x \ln x$ on the interval $1 \leq x \leq 2$ is

(A) $e^2 + \ln 2 + 1$ (B) $e^2 + 2 \ln 2$ (C) $e^{\pi/2} + \frac{\pi}{2} \ln \frac{\pi}{2}$ (D) $e^{3/2} + \frac{3}{2} \ln \frac{3}{2}$

Ans. [B]

Sol. $f'(x) = e^x + 1 + \ln x > 0$

$$(\text{as } x \in [1, 2])$$

$$\Rightarrow f(x) \text{ increases in } [1, 2]$$

$$\Rightarrow f_{\max} = f(2) = e^2 + 2 \ln 2$$

8. Let A be a 2×2 matrix of the form $A = \begin{bmatrix} a & b \\ 1 & 1 \end{bmatrix}$, where a, b are integers and $-50 \leq b \leq 50$. The number of such matrices A such that A^{-1} , the inverse of A, exists and A^{-1} contains only integer entries is
 (A) 101 (B) 200 (C) 202 (D) 101^2

Ans. [C]

Sol. $|A| \neq 0 \Rightarrow a - b \neq 0$

$$\Rightarrow a \neq b \quad \dots(i)$$

$$\text{Also, } A^{-1} = \frac{1}{a-b} \begin{bmatrix} 1 & -1 \\ -b & a \end{bmatrix}^T$$

$$= \frac{1}{a-b} \begin{bmatrix} 1 & -b \\ -1 & a \end{bmatrix}$$

Thus, $a - b = 1$ or -1 (ii)

So, required number of pairs (a, b) is $101 \times 2 = 202$

9. Let $A = (a_{ij})_{1 \leq i, j \leq 3}$ be a 3×3 invertible matrix where each a_{ij} is a real number. Denote the inverse of the matrix

A by A^{-1} . If $\sum_{j=1}^3 a_{ij} = 1$ for $1 \leq i \leq 3$, then

- (A) Sum of the diagonal entries of A is 1 (B) Sum of each row of A^{-1} is 1
 (C) Sum of each row and each column of A^{-1} is 1 (D) Sum of the diagonal entries of A^{-1} is 1

Ans. [B]

Sol. Sum of elements in each row of A is 1.

$$\text{so, } A \begin{bmatrix} 1 \\ 1 \\ 1 \end{bmatrix} = \begin{bmatrix} 1 \\ 1 \\ 1 \end{bmatrix}$$

$$\Rightarrow A^{-1} A \begin{bmatrix} 1 \\ 1 \\ 1 \end{bmatrix} = A^{-1} \begin{bmatrix} 1 \\ 1 \\ 1 \end{bmatrix}$$

$$\Rightarrow \begin{bmatrix} 1 \\ 1 \\ 1 \end{bmatrix} = A^{-1} \begin{bmatrix} 1 \\ 1 \\ 1 \end{bmatrix}$$

\Rightarrow Sum of elements in each row of A^{-1} is 1.

10. Let x, y be real numbers such that $x > 2y > 0$ and $2 \log(x-2y) = \log x + \log y$.

Then the possible value (s) of $\frac{x}{y}$

- (A) is 1 only (B) are 1 and 4 (C) is 4 only (D) is 8 only

Ans. [C]

Sol. $\log(x-2y)^2 = \log(xy)$

$$\Rightarrow (x-2y)^2 = xy$$

$$\Rightarrow \left(\frac{x-2y}{y}\right)^2 = \frac{x}{y}$$

$$\Rightarrow \left(\frac{x}{y}\right)^2 - 5\left(\frac{x}{y}\right) + 4 = 0$$

$$\Rightarrow \frac{x}{y} = 1, 4$$

$$\Rightarrow \frac{x}{y} = 4 \left(\text{as } \frac{x}{y} > 2 \right)$$

11. Let $\frac{x^2}{a^2} + \frac{y^2}{b^2} = 1$ ($b < a$), be an ellipse with major axis AB and minor axis CD. Let F_1 and F_2 be its two foci, with A, F_1 , F_2 , B in that order on the segment AB. Suppose $\angle F_1CB = 90^\circ$. The eccentricity of the ellipse is

- (A) $\frac{\sqrt{3}-1}{2}$ (B) $\frac{1}{\sqrt{3}}$ (C) $\frac{\sqrt{5}-1}{2}$ (D) $\frac{1}{\sqrt{5}}$

Ans. [C]

Sol. $\frac{b}{-ae} \times \frac{b}{a} = -1$

$$\Rightarrow b^2 = a^2 e$$

$$\Rightarrow a^2(1-e^2) = a^2 e$$

$$\Rightarrow e^2 + e - 1 = 0$$

$$\Rightarrow e = \frac{1+\sqrt{5}}{2}$$

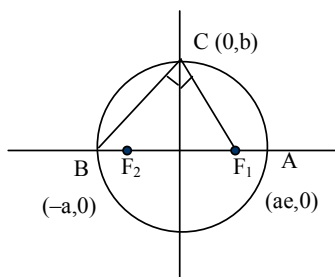

12. Let A denote the set of all real numbers x such that $x^3 - [x]^3 = (x - [x])^3$, where $[x]$ is the greatest integer less than or equal to x . Then
- (A) A is a discrete set of at least two points
 (B) A contains an interval, but is not an interval
 (C) A is an interval, but a proper subset of $(-\infty, \infty)$
 (D) $A = (-\infty, \infty)$

Ans. [B]

Sol. $(x - [x]) (x^2 + [x]^2 + x[x])$
 $= (x - [x]) (x^2 + [x]^2 - 2x[x])$
 $\Rightarrow (x - [x]) (3x[x]) = 0$
 $\Rightarrow x = 0$ or $[x] = 0$ $x = [x]$
 $\Rightarrow x \in \mathbb{Z} \cup [0, 1]$

13. Define a sequence $\{S_n\}$ of real numbers by

$$S_n = \sum_{k=0}^n \frac{1}{\sqrt{n^2 + k}}$$
 for $n \geq 1$

Then $\lim_{n \rightarrow \infty} S_n$

- (A) does not exist
 (B) exists and lies in the interval $(0, 1)$
 (C) exists and lies in the interval $[1, 2)$
 (D) exists and lies in the interval $[2, \infty)$

Ans. [B]

Sol. Since, $\sum_{k=0}^n \frac{1}{\sqrt{n^2 + n}} \leq \sum_{k=0}^n \frac{1}{\sqrt{n^2 + k}} \leq \sum_{k=0}^n \frac{1}{\sqrt{n^2 + 0}}$
 $\Rightarrow \lim_{n \rightarrow \infty} \frac{n}{\sqrt{n^2 + n}} \leq \lim_{n \rightarrow \infty} S_n \leq \lim_{n \rightarrow \infty} \frac{n}{\sqrt{n^2}}$
 $\Rightarrow 1 \leq \lim_{n \rightarrow \infty} S_n \leq 1$
 $\Rightarrow \lim_{n \rightarrow \infty} S_n = 1$

14. Let \mathbb{R} be the set of all real numbers and $f : \mathbb{R} \rightarrow \mathbb{R}$ be a continuous function. Suppose $|f(x) - f(y)| \geq |x - y|$ for all real numbers x and y . Then

- (A) f is one-one, but need not be onto
 (B) f is onto, but need not be one-one
 (C) f need not be either one-one or onto
 (D) f is one-one and onto

Ans. [D]

Sol. Let $f(x) = f(y)$
 so, $|f(x) - f(y)| \geq |x - y|$
 $\Rightarrow 0 \geq |x - y| \Rightarrow x - y = 0 \Rightarrow x = y$
 $\Rightarrow f$ is one-one
 Since, f is continuous
 So $f(0)$ is finite
 Now, $|f(x) - f(0)| \geq |x - 0|$
 $\Rightarrow \lim_{n \rightarrow \infty} |f(x) - f(0)| \geq \lim_{n \rightarrow \infty} |x|$
 $\Rightarrow \lim_{n \rightarrow \infty} f(x) = \infty$
 $\Rightarrow f$ is unbounded
 $\Rightarrow f$ is surjective

15. Let $f(x) = \begin{cases} \frac{x}{\sin x}, & x \in (0,1) \\ 1, & x = 0 \end{cases}$

Consider the integral

$$I_n = \sqrt{n} \int_0^{1/n} f(x)e^{-nx} dx$$

Then $\lim_{n \rightarrow \infty} I_n$

- (A) does not exist (B) exists and is 0 (C) exists and is 1 (D) exists and is $1 - e^{-1}$

Ans. [B]

Sol. $f(x)$ is an increasing function.

$$\text{so, } f(x) \in \left[1, \frac{1}{\sin 1}\right] \quad \forall x \in [0, 1)$$

Now,

$$\sqrt{n} \int_0^{1/n} e^{-nx} dx \leq \sqrt{n} \int_0^{1/n} f(x)e^{-nx} dx \leq \frac{\sqrt{n}}{\sin 1} \int_0^{1/n} e^{-nx} dx$$

$$\Rightarrow \lim_{n \rightarrow \infty} \frac{1 - \frac{1}{e}}{\sqrt{n}} \leq \lim_{n \rightarrow \infty} I_n \leq \frac{1 - \frac{1}{e}}{(\sin 1)\sqrt{n}}$$

$$\Rightarrow 0 \leq \lim_{n \rightarrow \infty} I_n \leq 0$$

$$\Rightarrow \lim_{n \rightarrow \infty} I_n = 0$$

16. The value of the integral

$$\int_1^3 ((x-2)^4 \sin^3(x-2) + (x-2)^{2019} + 1) dx \text{ is}$$

- (A) 0 (B) 2 (C) 4 (D) 5

Ans. [B]

Sol. $\int_1^3 ((x-2)^4 \sin^3(x-2) + (x-2)^{2019} + 1) dx$

$$x - 2 = t \Rightarrow dx = dt$$

$$\int_{-1}^1 (t^4 \sin^3 t + t^{2019} + 1) dt = \int_{-1}^1 dt = [t]_{-1}^1 = 2$$

17. In a regular 15-sided polygon with all its diagonals drawn, a diagonal is chosen at random. The probability that it is either a shortest diagonal nor a longest diagonal is

- (A) $\frac{2}{3}$ (B) $\frac{5}{6}$ (C) $\frac{8}{9}$ (D) $\frac{9}{10}$

Ans. [A]

Sol. Total diagonals = ${}^{15}C_2 - 15 = 90$

Shortest diagonal = Diagonal connecting

$$(A_1A_3, A_2A_4, \dots)$$

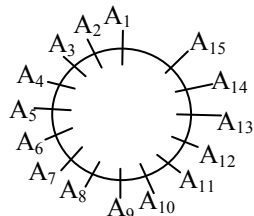

Longest diagonal = Diagonal connecting

$$(A_1 A_8, A_1 A_9, \dots)$$

$$= 15$$

$$\text{Required probability} = \frac{90 - 15 - 15}{90}$$

$$= \frac{60}{90} = \frac{2}{3}$$

18. Let $M = 2^{30} - 2^{15} + 1$ and M^2 be expressed in base 2. The number of 1's in this base 2 representation of M^2 is
 (A) 29 (B) 30 (C) 59 (D) 60

Ans. [B]

Sol. $(2^n)_2 = \underbrace{100\dots0}_{n \text{ times}}$

$$M^2 = (2^{60} - 2^{46}) + (2^{30} - 2^{16}) + 2^{31} + 1$$

$$= \left(\underbrace{11\dots1}_{14 \text{ times}} \underbrace{00\dots0}_{46 \text{ times}} + \underbrace{11\dots1}_{14 \text{ times}} \underbrace{1000\dots0}_{16 \text{ times}} + \underbrace{100\dots0}_{31 \text{ times}} + 1 \right)_2$$

$$\text{Number of 1's} = 14 + 1 + 14 + 1 = 30$$

19. Let ABC be a triangle such that $AB = 15$ and $AC = 9$. The bisector of $\angle BAC$ meets BC in D. If $\angle ACB = 2 \angle ABC$, then BD is

(A) 8 (B) 9 (C) 10 (D) 12

Ans. [C]

Sol.

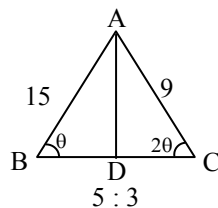

In $\triangle ABC$

$$\frac{15}{\sin 2\theta} = \frac{9}{\sin \theta} = \frac{BC}{\sin 3\theta}$$

$$\frac{15}{\sin 2\theta} = \frac{9}{\sin \theta} \Rightarrow \cos \theta = \frac{5}{6}$$

$$\frac{9}{\sin \theta} = \frac{BC}{\sin 3\theta}$$

$$\Rightarrow BC = 9[3 - 4 \sin^2 \theta]$$

$$= 9[4 \cos^2 \theta - 1]$$

$$= 9 \left[4 \times \frac{25}{36} - 1 \right]$$

$$= 16$$

$$\therefore BD = \frac{5}{8} BC = 10$$

20. The figure in the complex plane given by $10z\bar{z} - 3(z^2 + \bar{z}^2) + 4i(z^2 - \bar{z}^2) = 0$ is

(A) a straight line (B) a circle (C) a parabola (D) an ellipse

Ans. [A]

Sol. $10z\bar{z} - 3((z+\bar{z})^2 - 2z\bar{z}) + 4i((z+\bar{z})(z-\bar{z})) = 0$

Let $z = x + iy$

$$10(x^2 + y^2) - 3(4x^2 - 2x^2) + 4i(2x(2iy)) = 0$$

$$\Rightarrow 4x^2 + 16y^2 - 16xy = 0$$

$$\Rightarrow x^2 - 4xy + 4y^2 = 0$$

$$\Rightarrow (x - 2y)^2 = 0 \Rightarrow x = 2y$$

\therefore Straight line

PHYSICS

- 21.** Students A, B and C measure the length of a room using 25 m long measuring tape of least count (LC) 0.5 cm, meter-scale of LC 0.1 cm and a foot-scale of LC 0.05 cm, respectively. If the specified length of the room is 9.5 m, then which of the following students will report the lowest relative error in the measured length ?

(A) Student A (B) Student B (C) Student C (D) Both, student B and C

Ans. [A]

Sol. Student A : Length of scale = 25 m

Least count = 0.5 cm = 0.005m

Student A can measure the length of 9.5m by using the scale only once so there will be an error of 0.005m in 9.5 m

$$\therefore \text{Relative error} = \frac{0.005}{9.5} = 0.0005$$

Student B : Length of scale : 1 m = 100 cm

Least count = 0.05 cm

To measure 9.5m, student B has to use this meter scale atleast 10 times

$$\therefore \text{Relative error} = \frac{0.05}{100} \times 10 = 0.005 \text{ cm}$$

Student C : Length of scale : 1 foot = 30.48 cm

Least count = 0.05 cm

To measure 9.5m, student C has to use this scale approximately 31 times

$$\therefore \text{Relative error} = \frac{0.05}{30.48} \times 31 = 0.05 \text{ cm}$$

\therefore Relative error is least for Student A.

- 22.** Meena applies the front brakes while riding on her bicycle along a flat road. The force that slows her bicycle is provided by the

(A) front tyre (B) road (C) rear tyre (D) brakes

Ans. [B]

Sol. The frictional force on the tyres is an external force and is being provided by the road. Other options i.e. front tyre, rear tyre and brakes comprise the internal parts of bicycle thus forces applied by them will be internal only

- 23.** A proton and an antiproton come close to each other in vacuum such that the distance between them is 10 cm. Consider the potential energy to be zero at infinity. The velocity at this distance will be :

(A) 1.17 m/s (B) 2.3 m/s (C) 3.0 m/s (D) 23 m/s

Ans. [A]

Sol. Applying mechanical energy conservation

$$K_i + U_i = K_f + U_f$$

$$0 + 0 = \left(\frac{1}{2}mv^2 + \frac{1}{2}mv^2 \right) + \frac{k(q_1)(q_2)}{r}$$

$$|q_1| = |q_2| = e, \quad q_1 = +e$$

$$q_2 = -e$$

and $r = 0.1 \text{ m}$

$$\therefore mv^2 = \frac{ke^2}{r}$$

$$\therefore v^2 = \frac{ke^2}{mr} = \frac{9 \times 10^9 \times (1.6 \times 10^{-19})^2}{(1.67 \times 10^{-27})(0.1)}$$

$$v \approx 1.17 \text{ m/s}$$

24. A point particle is acted upon by a restoring force $-kx^3$. The time period of oscillation is T when the amplitude is A. The time period for an amplitude 2A will be :

(A) T (B) T/2 (C) 2T (D) 4T

Ans. [B]

Sol. Given $F = -kx^3$

$$-\frac{dU}{dx} = -kx^3$$

$$\Rightarrow U = \frac{1}{4} kx^4$$

\therefore Energy of oscillations will be

$$E = \frac{1}{2} mv^2 + U = \frac{1}{2} m \left(\frac{dx}{dt} \right)^2 + \frac{1}{4} kx^4 \dots(1)$$

If we pull $\frac{dx}{dt} = 0$ in above equation, we will

$$\text{get amplitude as } A = \sqrt[4]{\frac{4E}{k}} \dots(2)$$

Also on rearranging equation (1), we get

$$dt = \pm dx \sqrt{\frac{m}{2E}} \left(1 - \frac{k}{4E} x^4 \right)^{-1/2}$$

Now, use $A = \sqrt[4]{\frac{4E}{k}}$, to reduce above equation as

$$dt = \pm dx \sqrt{\frac{2m}{k}} A^{-2} \left(1 - \left(\frac{x}{A} \right)^4 \right)^{-1/2}$$

The time period can be found by integrating above equation.

$$T = 4 \int_0^A dx \sqrt{\frac{2m}{k}} A^{-2} \left(1 - \left(\frac{x}{A} \right)^4 \right)^{-1/2}$$

$$= 4 \sqrt{\frac{2m}{k}} A^{-2} \int_0^A \left(1 - \left(\frac{x}{A} \right)^4 \right)^{-1/2} dx$$

$$\text{Put } \frac{x}{A} = u \Rightarrow dx = Adu$$

$$\therefore T = 4 \sqrt{\frac{2m}{k}} A^{-2} (A) \int_0^1 du (1-u^4)^{-1/2}$$

$$T = 4 \sqrt{\frac{2m}{k}} A^{-1} (I)$$

where $I = \int_0^1 (1-u^4)^{-1/2} du$ is a numerical value

So from above equation $T \propto A^{-1}$

$$\therefore \frac{T_1}{T_2} = \frac{2A}{A} \Rightarrow T_2 = \frac{T}{2}$$

25. The output voltage (taken across the resistance) of a LCR series resonant circuit falls to half its peak value at a frequency of 200 Hz and again reaches the same value at 800 Hz. The bandwidth of this circuit is :
- (A) 200 Hz (B) $200\sqrt{3}$ Hz (C) 400 Hz (D) 600 Hz

Ans. [B]

Sol.

$$V_{\text{output}} = V_R$$

$$= i_{\text{rms}} R$$

$$= \frac{V_0 R}{Z} = \frac{V_0 R}{\sqrt{R^2 + (X_L - X_C)^2}}$$

$$\text{For peak } X_L = X_C \Rightarrow V_{\text{peak}} = V_0$$

$$\text{For } V_{\text{output}} = \frac{V_0}{2}$$

$$\frac{V_0}{2} = \frac{V_0 R}{\sqrt{R^2 + (X_L - X_C)^2}}$$

$$R^2 + (X_L - X_C)^2 = 4R^2$$

$$X_L - X_C = \pm \sqrt{3}R$$

$$\omega L - \frac{1}{\omega C} = \pm \sqrt{3}R$$

$$\omega^2 LC \mp \sqrt{3}R \omega C - 1 = 0$$

$$\omega = \frac{\pm \sqrt{3}RC \pm \sqrt{3R^2C^2 + 4LC}}{2LC}$$

$$\omega_1 = \frac{-\sqrt{3}RC + \sqrt{3R^2C^2 + 4LC}}{2LC} = 200 \times 2\pi$$

$$\omega_2 = \frac{+\sqrt{3}RC + \sqrt{3R^2C^2 + 4LC}}{2LC} = 800 \times 2\pi$$

$$\omega_2 - \omega_1 = 600 \times 2\pi = \sqrt{3} \frac{R}{L}$$

$$\text{Bandwidth} = \frac{R}{L} = \frac{2\pi \times 600}{\sqrt{3}}$$

$$\Delta f = \frac{1}{2\pi} \frac{R}{L} = \frac{600}{\sqrt{3}} = 200\sqrt{3}$$

26. A collimated beam of charged and uncharged particles is directed towards a hole marked P on a screen as shown below. If the electric and magnetic fields as indicated below are turned on

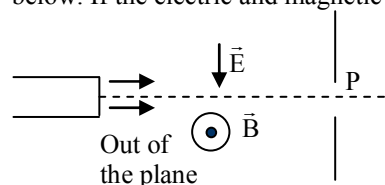

- (A) only particles with speed E/B will go through the hole P.
 (B) only charged particles with speed E/B and neutral particles will go through P.
 (C) only neutral particles will go through P.
 (D) Only positively charged particles with speed E/B and neutral particles will go through P.

Ans. [C]

Sol. For charged particles

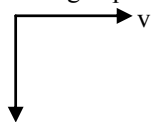

$$qE + qvB$$

net force is in downward direction, so they won't be able to go through the hole P.

And uncharged particle don't deviate so they will be able to go through hole P.

27. An engine runs between a reservoir at temperature 200 K and a hot body which is initially at temperature of 600 K. If the hot body cools down to a temperature of 400 K in the process, then the maximum amount of work that the engine can do (while working in a cycle) is (the heat capacity of the hot body is 1 J/K)

- (A) $200(1 - \ln 2)$ J (B) $200(1 - \ln 3/2)$ J (C) $200(1 + \ln 3/2)$ J (D) 200 J

Ans. [B]

Sol. $\eta = \frac{W}{Q_{in}}$

$$\Rightarrow W = \eta Q_{in}$$

$$Q = \int C dt$$

For maximum amount of work, efficiency should be maximum, means we have to assume carnot engine.

$$\therefore \eta = 1 - \frac{T_2}{T_1} = 1 - \frac{200}{T}$$

$$\therefore W = \int nQ_{in} = - \int_{600}^{400} \left(1 + \frac{200}{T}\right) CdT$$

$$= -C [T - 200 \ln T]_{600}^{400}$$

$$W = -C \left[-200 + \ln \left(\frac{3}{2}\right) 200 \right]$$

$$C = 1 \text{ (Given)}$$

$$\therefore W = 200 - 200 \ln \left(\frac{3}{2}\right)$$

$$W = 200 \left(1 - \ln \left(\frac{3}{2}\right)\right)$$

28. The clocktower ("ghantaghar") of Dehradun is famous for the sound of its bell, which can be heard, albeit faintly, upto the outskirts of the city 8 km away. Let the intensity of this faint sound be 30 dB. The clock is situated 80 m high. The intensity at the base of the tower is :-

- (A) 60 dB. (B) 70 dB. (C) 80 dB. (D) 90 dB.

Ans. [B]

Sol. $r_2 = 80\text{m}$, $L_2 = ?$

$$r_1 = 8000 \text{ m}, L_1 = 30 \text{ dB}$$

$$L = 10 \log_{10} \left(\frac{I}{I_0}\right)$$

$$\text{Intensity due to point source, } I \propto \frac{1}{r^2}$$

$$L_2 - L_1 = 10 \log_{10} \left(\frac{I_2}{I_0}\right) - 10 \log_{10} \left(\frac{I_1}{I_0}\right)$$

$$L_2 - L_1 = 10 \log_{10} \left(\frac{I_2}{I_1}\right) = 10 \log_{10} \left(\frac{r_1^2}{r_2^2}\right)$$

$$L_2 - 30 = 10 \log_{10} (10^4) = 40$$

$$L_2 = 70 \text{ dB}$$

29. An initially uncharged capacitor C is being charged by a battery of emf E through a resistance R upto the instant when the capacitor is charged to the potential E/2, the ratio of the work done by the battery to the heat dissipated by the resistor is given by
 (A) 2 : 1 (B) 3 : 1 (C) 4 : 3 (D) 4 : 1

Ans. [C]
 Sol.

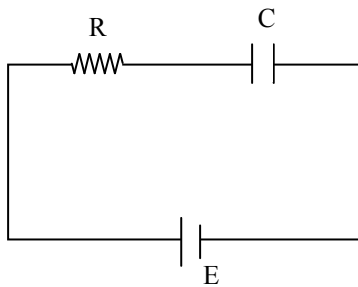

$$i = \frac{E}{R} e^{-t/RC}, \quad Q = CE (1 - e^{-t/RC})$$

Capacitor is charged to $\frac{E}{2}$,

$$\text{So } Q = \frac{CE}{2}$$

$$\therefore \frac{CE}{2} = CE (1 - e^{-t/RC})$$

$$\frac{1}{2} = e^{-t/RC}$$

$$t = RC \ln 2$$

Work done by battery = $(Q_{\text{flow}}) (\Delta V)$

$$= \left(\frac{CE}{2} \right) (E) = \frac{CE^2}{2}$$

$$\text{Heat dissipated} = \int_0^{RC \ln 2} i^2 R dt$$

$$= \frac{E^2}{R} \int_0^{RC \ln 2} e^{-2t/RC} dt$$

$$= \frac{3}{4} \left(\frac{CE^2}{2} \right)$$

$$\frac{\text{Work done}}{\text{Heat dissipated}} = \frac{CE^2/2}{\frac{3}{4} \left(\frac{CE^2}{2} \right)} = \frac{4}{3}$$

30. Consider a sphere of radius R with uniform charged density and total charge Q. The electrostatic potential distribution inside the sphere is given by

$\phi(r) = \frac{Q}{4\pi\epsilon_0 R} (a + b(r/R)^c)$. Note that the zero of potential is at infinity. The values of (a, b, c) are :-

- (A) $\left(\frac{1}{2}, -\frac{3}{2}, 1 \right)$ (B) $\left(\frac{3}{2}, -\frac{1}{2}, 2 \right)$ (C) $\left(\frac{1}{2}, \frac{1}{2}, 1 \right)$ (D) $\left(\frac{1}{2}, -\frac{1}{2}, 2 \right)$

Ans. [B]

Sol. Potential inside uniformly charged solid sphere is given by

$$V = \frac{kQ}{2R^3} [3R^2 - r^2]$$

$$= \frac{kQ}{R} \left[\frac{3R^2}{2R^2} - \frac{r^2}{2R} \right]$$

$$= \frac{Q}{4\pi\epsilon_0 R} \left[\frac{3}{2} - \frac{1}{2} \left(\frac{r}{R} \right)^2 \right]$$

Compare with given formula i.e,

$$\frac{Q}{4\pi\epsilon_0 R} \left[a + b \left(\frac{r}{R} \right)^c \right]$$

$$a = \frac{3}{2}, b = -\frac{1}{2}, c = 2$$

31. The efficiency of the cycle shown below in the figure (consisting of one isobar, one adiabat and one isotherm) is 50%. The ratio, x between the highest and lowest temperatures attained in this cycle obeys (the working substance is a ideal gas) :-

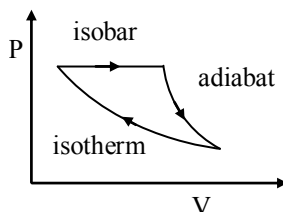

(A) $x = e^{x-1}$

(B) $x^2 = e^{x-1}$

(C) $x = e^{x-1}$

(D) $x^2 = e^{x^2-1}$

Ans.
Sol.

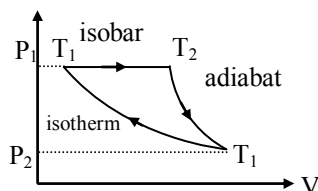

$$\frac{C_p}{C_p - R} = \gamma$$

$$C_p = \gamma C_p - \gamma R$$

$$\gamma R \Rightarrow (\gamma - 1) C_p$$

$$\frac{\gamma R}{\gamma - 1} = C_p$$

$$\eta = \frac{\text{Work done}}{\text{Heat supplied}}$$

$$\eta = \frac{nC_p \Delta T - nRT \ln \left(\frac{P_1}{P_2} \right)}{nC_p \Delta T} = \frac{1}{2}$$

$$\eta C_p \Delta T = 2nRT \ln \frac{P_1}{P_2}$$

$$\left(\frac{P_1}{P_2} \right)^{1-\gamma} = \left(\frac{T_1}{T_2} \right)^\gamma$$

$$\frac{\gamma R}{\gamma - 1} (T_2 - T_1) = 2RT_1 \ln \left(\frac{T_1}{T_2} \right)^{\frac{\gamma}{1-\gamma}}$$

$$T_2 - T_1 = 2T_1 \ln \left(\frac{T_2}{T_1} \right)$$

$$x - 1 = \ln(x^2)$$

$$x^2 = e^{x-1}$$

32. A right-angle isosceles prism is held on the surface of a liquid composed of miscible solvents A and B of refractive index $n_A = 1.50$ and $n_B = 1.30$, respectively. The refractive index of prism is $n_p = 1.5$ and that of the liquid is given by $n_L = C_A n_A + (1 - C_A) n_B$, where C_A is the percentage of solvent A in the liquid :-

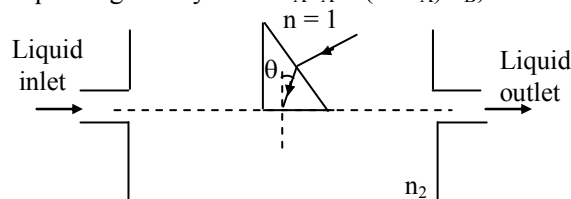

If θ_c is the critical angle at prism-liquid interface, the plot which best represents the variation of the critical angle with the percentage of solvent is :

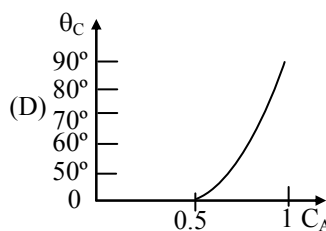
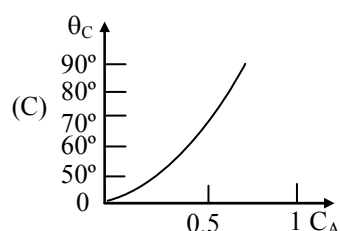
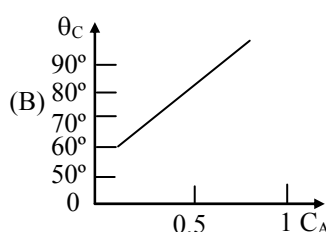
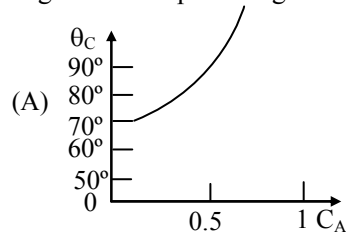

Ans. [A]

Sol. $n_p \sin \theta_c = n_L \sin 90^\circ$

$$\theta_c = \sin^{-1} \left(\frac{n_L}{n_p} \right)$$

$$\theta_c = \sin^{-1} \frac{C_A n_A + (1 - C_A) n_B}{1.5}$$

→ Graph between θ_c and C_A will be curve of \sin^{-1}
Check for $C_A = 0.5$, to find most appropriate graph

$$\theta_c = \sin^{-1} \left(\frac{0.5(1.5) + 0.5(1.3)}{1.5} \right)$$

$$\theta_c = \sin^{-1} \left(\frac{14}{15} \right) \approx 69^\circ$$

∴ Correct option is (A)

13. Instead of angular momentum quantization a student posits that energy is quantized as $E = -E_0/n$ ($E_0 > 0$) and n is a positive integer. Which of the following options is correct ?

- (A) The radius of the electron orbit is $r \propto \sqrt{n}$.
 (B) The speed of the electron is $v \propto \sqrt{n}$.
 (C) The angular speed of the electron is $\omega \propto 1/n$
 (D) The angular momentum of the electron is $\propto \sqrt{n}$.

Ans. [D]

Sol. $F_e = \frac{mv^2}{r} \Rightarrow \frac{mv^2}{r} = \frac{k(Ze)(e)}{r^2}$

$$\frac{1}{2} mv^2 = \frac{KZe^2}{2r} \dots (i) \text{ (Kinetic energy)}$$

$$\text{Potential energy} = \frac{Kq_1q_2}{r} = \frac{K(Ze)(-e)}{r} \dots (ii)$$

$$\text{Total energy} = KE + PE = -\frac{KZe^2}{2r} = -\frac{E_0}{n}$$

$$\therefore r \propto n$$

$$\text{As kinetic energy} = \frac{KZe^2}{2r} \Rightarrow KE \propto \frac{1}{n}$$

$$\text{or } v^2 \propto \frac{1}{n} \Rightarrow v \propto \frac{1}{\sqrt{n}}$$

$$L = mvr$$

$$L \propto vr$$

$$L \propto \frac{1}{\sqrt{n}} (n) \propto \sqrt{n}$$

$$\Rightarrow L \propto \sqrt{n}$$

34. A monochromatic beam of light is incident at the interface of two materials of refractive index n_1 and n_2 as shown. If $n_1 > n_2$ and θ_c is the critical angle then which of the following statements is NOT true ?

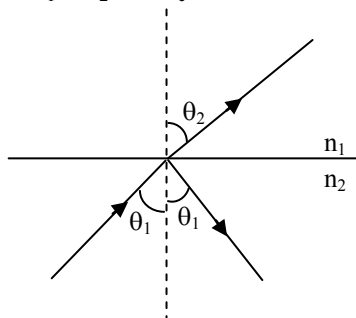

(A) $\theta_1 = \theta_3$ for all values of θ_1 .

(B) $\cos\theta_2$ is imaginary for $\theta_1 > \theta_c$.

(C) $\cos\theta_2 = 0$ for $\theta_1 = \theta_c$.

(D) $\cos\theta_3$ is imaginary for $\theta_1 = \theta_c$.

Ans. [D]

Sol. $n_1 > n_2$

this means light is going from rarer to denser medium.

So θ_2 will always be less than θ_1

$$n_2 \sin\theta_1 = n_1 \sin\theta_2$$

so $\cos(\theta_2)$ will never be imaginary and also θ_2 can't be 90°

In question incorrect options are asked.

\therefore (B,C,D)

35. The intensity of light from a continuously emitting laser source operating at 638 nm wavelength is modulated at 1 GHz. The modulation is done by momentarily cutting the intensity off with a frequency of 1 GHz. What is the farthest distance apart two detectors can be placed in the line of the laser light, so that they can see the portions of the same pulse simultaneously ? (Consider the speed of light in air 3×10^8 m/s) :-

(A) 30 μ m

(B) 30 cm

(C) 3 m

(D) 30 m

Ans. [B]

Sol. Time period between two flashes = $\frac{1}{f}$

Distance travelled by laser in this interval

$$= \frac{c}{f} = \frac{3 \times 10^8}{10^9} = 0.3 \text{ m} = 30 \text{ cm}$$

So this is the maximum distance between two detectors, so that they can see the same pulse simultaneously.

36. A conducting rod, with a resistor of resistance R , is pulled with constant speed v on a smooth conducting rail as shown in figure. A constant magnetic field \vec{B} is directed into the page. If the speed of the bar is doubled, by what factor does the rate of heat dissipation across the resistance R change ?

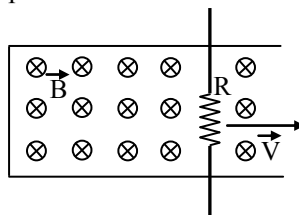

- (A) 0 (B) $\sqrt{2}$ (C) 2 (D) 4

Ans. [D]

Sol. Emf = VBL

$$I = \frac{VBL}{R}$$

$$\text{Heat} = I^2 R = \frac{V^2 B^2 L^2}{R}$$

Given $V^1 = 2V$

$$\text{So } \frac{H^1}{H} = 4$$

37. The time period of a body undergoing simple harmonic motion is given by $T = p^a D^b S^c$, where p is the pressure, D is density and S is surface tension. The values of a , b and c respectively are

- (A) $1, \frac{1}{2}, \frac{3}{2}$ (B) $\frac{3}{2}, -\frac{1}{2}, 1$ (C) $1, -\frac{1}{2}, \frac{3}{2}$ (D) $-\frac{3}{2}, \frac{1}{2}, 1$

Ans. [D]

Sol. $[T] = [m^a L^{-a} T^{-2a} m^b L^{-3b} m^c T^{-2c}]$

$$[T] = [m^{a+b+c} L^{-a-3b} T^{-2a-2c}]$$

$$a + b + c = 0$$

$$-a - 3b = 0$$

$$-2a - 2c = 1$$

On solving

$$a = \frac{-3}{2}, b = \frac{1}{2}, c = 1$$

38. Consider the following statements regarding the real images formed with a converging lens.

(I) Real images can be seen only if the image is projected onto the screen

(II) The real image can be seen only from the same side of the lens as that on which the object is positioned.

(III) Real images produced by converging lenses are not only laterally but also longitudinally inverted as with mirrors.

Which of the above statement/ statements is/ are incorrect ?

- (A) Only I and III (B) All three (C) None (D) Only II

Ans. [B]

Sol. Theoretical \rightarrow B

39. A zinc ball of radius, $R = 1$ cm charged to a potential -0.5 V. The ball is illuminated by a monochromatic ultraviolet (UV) light with a wavelength 290 nm. The photoelectric threshold for zinc is 332 nm. The potential of ball after a prolonged exposure to the UV is
 (A) -0.5 V (B) 0 V (C) 0.54 V (D) 0.79 V

Ans. [C]

Sol. $\phi = \frac{12431}{3320} = 3.74$ eV

$$\varepsilon = \frac{hc}{\lambda} = \frac{12431}{2900} = 4.28 \text{ eV}$$

$$(\text{KE})_{\text{max}} = 4.28 - 3.74 = 0.54 \text{ eV}$$

Initially sphere is negatively charged so e^- will go easily then potential becomes 0 . After that as e^- will leave the potential will increase till it reaches the stopping potential value, V_0

$$eV_0 = 0.54 \text{ eV}$$

$$V_0 = 0.54 \text{ V}$$

40. A source simultaneously emitting light at two wavelengths 400 nm and 800 nm is used in the Young's double slit experiment. If the intensity of light at the slit for each wavelength is I_0 , then the maximum intensity that can be observed at any point on the screen is
 (A) I_0 (B) $2 I_0$ (C) $4 I_0$ (D) $8 I_0$

Ans. [D]

Sol. At central maxima

$$\text{Due to } 400 \text{ nm} = 4I_0$$

$$\text{Due to } 800 \text{ nm} = 4I_0$$

$$\text{Total Intensity} = 8 I_0$$

CHEMISTRY

41. The stability of

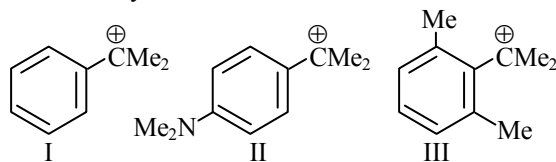

follows the order :

(A) $I > II > III$

(B) $II > I > III$

(C) $II > III > I$

(D) $III > II > I$

Ans. [B]

Sol.

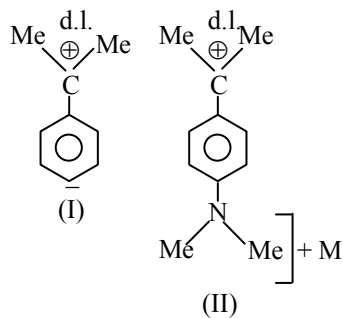

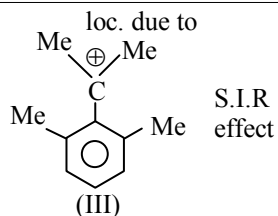

stability : II > I > III

Note : In III carbocation is localised due to S.I.R. effect

42. Among the following, the biodegradable polymer is :
 (A) polylactic acid (B) polyvinyl chloride (C) bakelite (D) teflon

Ans. [A]

Sol. Polyacetic acid is biodegradable polymer,

43. Among the following,

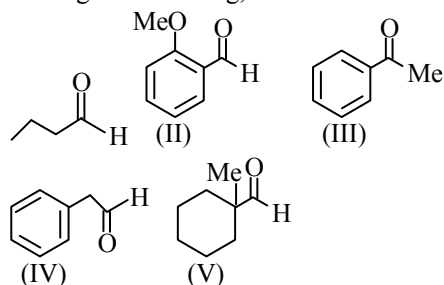

The compounds which can be reduced with formaldehyde and conc. aq. KOH, are :

- (A) only II and V (B) only I and V (C) only II and III (D) only I, II and IV

Ans. [A]

Sol. Aldehyde without α -H give Cannizaro reaction.

In Cannizaro reaction alcohol and carboxylic acid salt is formed.

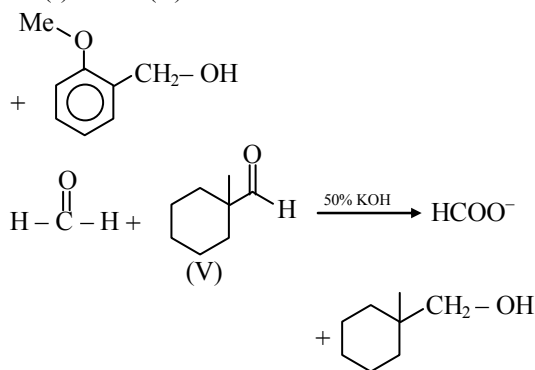
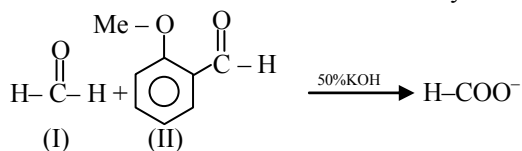

44. An organic compound that is commonly used for sanitizing surfaces is :

- (A) acetylsalicylic acid
 (B) chloramphenicol
 (C) aspartame
 (D) cetyltrimethyl ammonium bromide

Ans. [D]

Sol. Cetyltrimethyl ammonium bromide is used for sanitizing agent.

45. The rates of reaction of NaOH with :

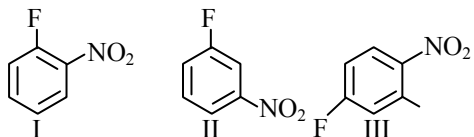

follow the order : -

- (A) II > I > III (B) II > III > I (C) I > III > II (D) III > II > I

Ans. [C]

Sol.

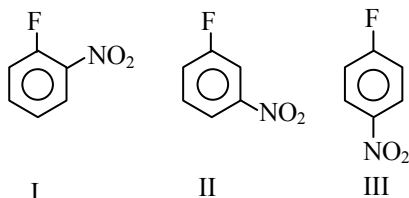

I and II can react with NaOH but II do not react at room temperature. I and III give reaction because at O and P position electrone withdrawing group is present.

46. The most suitable reagent for the conversion of 2-phenylpropanamide into 1-phenylethylamine is : -

- (A) $H_2, Pd/C$ (B) $Br_2, NaOH$ (C) $LiAlH_4, Et_2O$ (D) $NaBH_4, MeOH$

Ans. [B]

Sol.

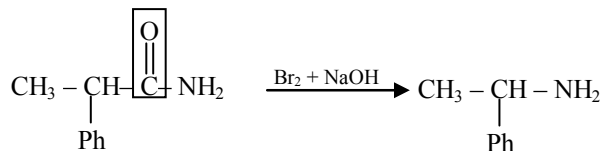

47. The compound X in the following reaction scheme :

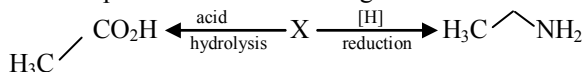

is : -

- (A) acetonitrile (B) methyl isocyanide (C) acetaldehyde (D) nitromethane

Ans. [A]

Sol.

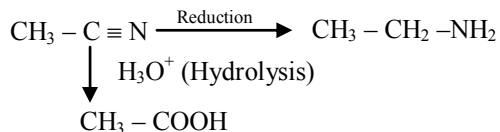

$CH_3 - CN$ is common name \Rightarrow Acetonitrile

48. A nucleus X captures a β particle and then emits a neutron and γ ray to form Y. X and Y are : -

- (A) isomorphs (B) isotopes (C) isobars (D) isotones

Ans. [D]

Sol.

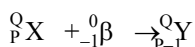

X and Y has same mass number, hence they are isotones.



49. The boiling point (in °C) of 0.1 molal aqueous solution of $\text{CuSO}_4 \cdot 5\text{H}_2\text{O}$ at 1 bar is closest to :
 [Given : Ebullioscopic (molal boiling point elevation) constant of water, $K_b = 0.512 \text{ K Kg mol}^{-1}$] : -
 (A) 100.36 (B) 99.64 (C) 100.10 (D) 99.90

Ans. [C]

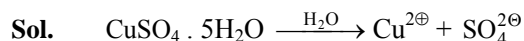

$$i = 2$$

$$\Delta T_b = i \cdot K_b \cdot m = 2 \times 0.512 \times 0.1 = 0.1024$$

$$T_b' = T_b^0 + \Delta T_b = 100 + 0.1024 = 100.10$$

50. A weak acid is titrated with a weak base. Consider the following statements regarding the pH of the solution at the equivalence point :

- (i) pH depends on the concentration of acid and base,
 (ii) pH is independent of the concentration of acid and base
 (iii) pH depends on the pK_a of acid and pK_b of base.
 (iv) pH is independent of the pK_a of acid and pK_b of base.

The correct statement are : -

- (A) only (i) and (iii) (B) only (i) and (iv) (C) only (ii) and (iii) (D) only (ii) and (iv)

Ans. [C]

Sol. For salts of weak acid and weak base

$$\text{pH} = 7 + \frac{1}{2} (\text{pK}_a - \text{pK}_b)$$

pH is independent of concentration of acid and base

51. Products are favoured in a chemical reaction taking place at a constant temperature and pressure. Consider the following statement :

- (i) The change in Gibbs energy for the reaction is negative.
 (ii) The total change in gibbs energy for the reaction and the surroundings is negative.
 (iii) The change in entropy for the reaction is positive.
 (iv) The total change in entropy for the reaction and the surroundings is positive

The statements which are ALWAYS true are : -

- (A) only (i) and (iii) (B) only (i) and (iv) (C) only (ii) and (iv) (D) only (ii) and (iii)

Ans. [B]

Sol. Since products are formed in the chemical reaction taking place at constant temperature and pressure, we can say that the reaction is spontaneous

Hence,

$$\Delta G_{\text{reaction}} < 0$$

$$\Delta S_{\text{total}} > 0$$

52. A mixture of toluene and benzene forms a nearly ideal solution. Assume P_B° and P_T° to be the vapor pressures of pure benzene and toluene, respectively. The slope of the line obtained by plotting the total vapor pressure to the mole fraction of benzene is

- (A) $P_B^\circ - P_T^\circ$ (B) $P_T^\circ - P_B^\circ$ (C) $P_B^\circ + P_T^\circ$ (D) $(P_B^\circ + P_T^\circ)/2$

Ans. [A]

Sol. $P_{\text{total}} = \chi_B (P_B^\circ) + \chi_T (P_T^\circ) = \chi_B (P_B^\circ) + (1 - \chi_B) (P_T^\circ)$

Comparing it with $y = mx + c$

$$\frac{P_{\text{total}}}{y} = \frac{\chi_B}{x} \left[\frac{(P_B^\circ - P_T^\circ)}{m} \right] + \frac{P_T^\circ}{c}$$

53. Upon dipping a copper rod, the aqueous solution of the salt that can turn blue is : -
 (A) $\text{Ca}(\text{NO}_3)_2$ (B) $\text{Mg}(\text{NO}_3)_2$ (C) $\text{Zn}(\text{NO}_3)_2$ (D) AgNO_3

Ans. [D]

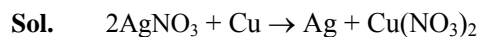

Metal can reduce that metal cation which is placed below it in reactivity series.

54. Treatment of alkaline KMnO_4 solution with KI solution oxidizes iodide to
 (A) I_2 (B) IO_4^- (C) IO_3^- (D) IO_2^-

Ans. [C]

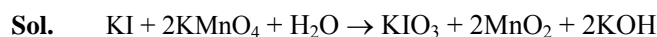

55. If an extra electron is added to the hypothetical molecule C_2 , this extra electron will occupy the molecular orbital : -
 (A) π_{2p}^* (B) π_{2p} (C) σ_{2p}^* (D) σ_{2p}

Ans. [D]

Sol. Configuration of C_2

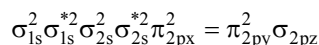

an extra electron added to the σ_{2p} of the above configuration.

56. Among the following, the square planar geometry is exhibited by :
 (A) CdCl_4^{2-} (B) $\text{Zn}(\text{CN})_4^{2-}$ (C) PdCl_4^{2-} (D) $\text{Cu}(\text{CN})_4^{3-}$

Ans. [C]

| Complex | Shape | Hybridisation. |
|---------------------------------|---------------|----------------|
| $[\text{CdCl}_4]^{2-}$ | Tetrahedral | sp^3 |
| $[\text{Zn}(\text{CN})_4]^{2-}$ | Tetrahedral | sp^3 |
| $[\text{PdCl}_4]^{2-}$ | Square Planar | dsp^2 |
| $[\text{Cu}(\text{CN})_4]^{3-}$ | Tetrahedral | sp^2 |

57. The correct pair of orbitals involved in π -bonding between metal and CO in metal carbonyl complexes is
 (A) metal d_{xy} and carbonyl π_x^*
 (B) metal d_{xy} and carbonyl π_x
 (C) metal $d_{x^2-y^2}$ and carbonyl π_x^*
 (D) metal $d_{x^2-y^2}$ and carbonyl π_x

Ans. [A]

Sol.

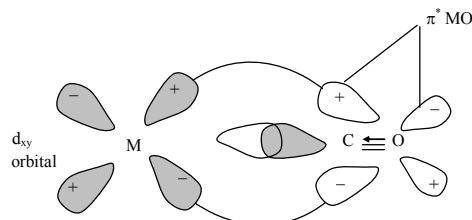

58. The magnetic moment (in μ_B) of $[\text{Ni}(\text{dimethylglyoximate})_2]$ complex is closest to
 (A) 5.37 (B) 0.00 (C) 1.73 (D) 2.25

Ans. [B]

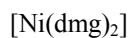
Sol.

No unpaired electron present in split 'd' orbital

∴ diamagnetic ($\mu_B = 0$).

59. A compound is formed by two elements M and N. Element N forms hexagonal closed pack array with 2/3 of the octahedral holes occupied by M. The formula of the compound is

- (A) M₄N₃ (B) M₂N₃ (C) M₃N₂ (D) M₃N₄

Ans. [B]**Sol.** Number of atoms of element 'N' per unit cell = 6 Number of atoms of element M per unit cell

$$= \frac{2}{3} (\text{Number of octahedral voids per unit cell})$$

$$= \frac{2}{3} \times 6 = 4$$

$$M : N = 4 : 6 = 2 : 3$$

Formula is M₂N₃

60. If the velocity of the revolving electron of He⁺ in the first orbit (n = 1) is v, the velocity of the electron in the second orbit is :

- (A) v (B) 0.5 v (C) 2v (D) 0.25 v

(D) This reaction involves an induced fit mechanism in hexokinase

Ans. [B]**Sol.** For single electron species $v_n \propto \frac{1}{n}$

$$\frac{v_2}{v_1} = \frac{n_1}{n_2} = \frac{1}{2}$$

$$v_2 = \frac{1}{2} v_1 = \frac{1}{2} v = \frac{v}{2} = 0.5v$$

BIOLOGY

61. Species with high fecundity, high growth rates, and small body sizes are typically
 (A) endangered species (B) keystone species (C) K-selected species (D) r-selected species

Ans. [D]**Sol.**

62. When RNase enzyme is denatured by adding urea, which ONE of the following combinations of bonds would be disrupted ?

- (A) Ionic and disulphide bond (B) Ionic and hydrogen bonds
 (C) Hydrogen and peptide bonds (D) Peptide and disulphide bonds

Ans. [B]**Sol.**

63. The function of aposematic colouration is to

- (A) attract mates (B) camouflage (C) scare off competitors (D) warn predators .

Ans. [D]**Sol.**

64. Maize and rice genomes have diploid chromosome number of 20 and 24, respectively. In the absence of crossing over and mutations, which ONE of the following is CORRECT about the genetic variation among their offspring?
(A) maize < rice (B) maize = rice > 0 (C) maize = rice = 0 (D) maize > rice
Ans. [D]
Sol.
65. The exponent z of the species-area curve measured at continental scales is
(A) smaller than the value of z at regional scales. (B) equal to the value of z at regional scales.
(C) greater than the value of z at regional scales. (D) unrelated to the value of z at regional scales.
Ans. [C]
Sol.
66. The pH of an aqueous solution of 10^{-8} M HCl is
(A) 6.0 (B) between 6.9 – 7.0 (C) between 7.0 – 7.1 (D) 8.0
Ans. [B]
Sol.
67. Which ONE of the following can NOT cause eutrophication of lakes ?
(A) Introduction of invasive floating plants
(B) Discharge of fertilizer-rich agricultural waste
(C) Natural ageing of lakes
(D) discharge of industrial waste
Ans. [D]
Sol.
68. Which ONE of the following polymerases transcribes 5S rRNA?
(A) RNA Pol I (B) RNA Pol III (C) RNA Pol II (D) RNA Pol IV
Ans. [B]
Sol.
69. Which ONE of the following statements about rennin is CORRECT?
(A) It is secreted by adrenal glands
(B) It converts angiotensinogen to angiotensin.
(C) It is secreted by peptic cells of gastric glands into the stomach.
(D) It is a hormone.
Ans. [C]
Sol.
70. When one goes from a brightly lit area to a dimly lit room our eyes adjust slowly, thereby regaining the clarity of vision. Which ONE of the following explains this process ?
(A) Regeneration of rhodopsin in the rod cells (B) Bleaching of rhodopsin
(C) Constriction of the pupil (D) Increase in the number of rod cells
Ans. [A]
Sol.
71. In a diploid population at Hardy-Weinberg equilibrium, consider a locus with two alleles. The frequencies of these two alleles are denoted by p and q , respectively. Heterozygosity in this population is maximum at
(A) $p = 0.25$, $q = 0.75$ (B) $p = 0.4$, $q = 0.6$ (C) $p = 0.6$, $q = 0.4$ (D) $p = 0.5$, $q = 0.5$
Ans. [D]
Sol.

72. An enzyme with optimal activity at pH 2.0 and 37°C is most likely to be :
 (A) lysozyme from hen egg white (B) trypsin from cattle
 (C) DNA polymerase from *Thermus aquaticus* (D) pepsin from humans

Ans. [D]
 Sol.

73. While adjusting to varying environmental temperature, plants incorporate in their plasma membrane
 (A) more saturated fatty acids in cold and more unsaturated fatty acids in hot environment.
 (B) more unsaturated fatty acids in cold and more saturated fatty acids in hot environment.
 (C) more saturated fatty acids in both cold and hot environment.
 (D) more unsaturated fatty acids in both cold and hot environment.

Ans. [B]
 Sol.

74. Which ONE of the following terms is NOT used while describing human vertebra ?
 (A) Lumbar (B) Sacral (C) Thoracic (D) Tarsal

Ans. [D]
 Sol.

75. Assume a population that has reached herd immunity for an infectious disease. If an infected individual is introduced to this population, which of the following is most likely to occur ?
 (A) The infection will spread exponentially across the population.
 (B) The infection will spread linearly across the population.
 (C) A few individuals may get infected, but the infection will not spread across the population.
 (D) No other individual will be infected by the disease.

Ans. [C]
 Sol.

76. Match the type of cells in Column I with the organs they are part of, listed in Column II :

Column I
 P. Chondroblast
 Q. Osteoclast
 R. Microglia
 S. Pneumocyte

Column II
 i. Bone
 ii. Brain
 iii. Cartilage
 iv. Lung

Choose the CORRECT combination.

- (A) P-iii, Q-i, R-ii, S-iv (B) P-ii, Q-i, R-iii, S-iv
 (C) P-iv, Q-iii, R-ii, S-i (D) P-iii, Q-ii, R-iv, S-i

Ans. [A]
 Sol.

77. A bacterial culture was started with an inoculum of 10 cells. What will be the number of cells at the end of 10 cycles of division, assuming that every progeny cell undergoes division in each cycle ?

- (A) 100 (B) 1024 (C) 2048 (D) 10240

Ans. [D]
 Sol.

78. The following family tree traces the occurrence of a rare genetic disease. The filled symbols signify the individuals with the disease, whereas the open symbols signify health individuals.

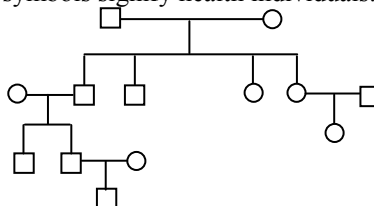

Based on this information, the disease is most likely to be

- (A) autosomal, dominant (B) autosomal, recessive
 (C) X-linked, recessive (D) X-linked, dominant

Ans. [B]
 Sol.

79. Which ONE of the following statements is CORRECT about the mechanism of action of penicillin ?
 (A) It inhibits transcription (B) It hydrolyses cell wall
 (C) It inhibits cell wall biosynthesis (D) It inhibits translation

Ans. [C]

Sol.

80. Leaf extract from an infected plant was passed through a filter with a pore size of $0.05 \mu\text{m}$ diameter. The infectious agent was detected in the filtrate. Which ONE of the following is the likely infectious agent ?
 (A) Bacteria (B) Virus (C) Nematode (D) Fungus

Ans. [B]

Sol.

Part – II

Two - Mark Questions

MATHEMATICS

81. Let

$$a = \sum_{n=101}^{200} 2^n \sum_{k=101}^n \frac{1}{k!}$$

and

$$b = \sum_{n=101}^{200} \frac{2^{201} - 2^n}{n!}$$

Then $\frac{a}{b}$ is

- (A) 1 (B) $\frac{3}{2}$ (C) 2 (D) $\frac{5}{2}$

Ans. [A]

Sol.

$$\begin{aligned} a &= \sum_{n=101}^{200} 2^n \sum_{k=101}^n \frac{1}{k!} \\ &= \frac{2^{101}}{101!} + 2^{102} \left(\frac{1}{101!} + \frac{1}{102!} \right) + 2^{103} \left(\frac{1}{101!} + \frac{1}{102!} + \frac{1}{103!} \right) + \dots \\ &\quad + 2^{200} \left(\frac{1}{101!} + \frac{1}{102!} + \dots + \frac{1}{200!} \right) \\ &= \frac{2^{101} + \dots + 2^{200}}{101!} + \frac{2^{102} + \dots + 2^{200}}{102!} + \dots + \frac{2^{200}}{200!} \\ &= \frac{2^{101}(2^{100} - 1)}{101!} + \frac{2^{102}(2^{99} - 1)}{102!} + \dots + \frac{2^{200}}{200!} \\ &= \left(\frac{2^{201}}{101!} - \frac{2^{101}}{101!} \right) + \left(\frac{2^{201}}{102!} - \frac{2^{102}}{102!} \right) + \dots + \left(\frac{2^{201}}{200!} - \frac{2^{202}}{200!} \right) \\ &= \sum_{n=101}^{200} \frac{2^{201} - 2^n}{n!} = b \\ \therefore \frac{a}{b} &= 1 \end{aligned}$$

82. Let a, b, c be non zero real roots of the equation $x^3 + ax^2 + bx + c = 0$. Then
 (A) there are infinitely many such triples a, b, c (B) there is exactly one such triple a, b, c
 (C) there are exactly two such triples a, b, c (D) there are exactly three such triples a, b, c

Ans. [C]

Sol. $x^3 + ax^2 + bx + c = 0 = (x - a)(x - b)(x - c)$

$$a + b + c = -a$$

$$\Rightarrow 2a + b + c = 0 \quad \dots(i)$$

$$ab + bc + ca = b \quad \dots(ii)$$

$$abc = -c \Rightarrow ab = -1 \quad [\because c \neq 0] \dots(iii)$$

Also a is a root of equation

$$\Rightarrow 2a^3 + ab + c = 0 \Rightarrow 2a^3 - 1 + c = 0$$

$$\Rightarrow c = 1 - 2a^3$$

from (1)

$$2a^2 + ab + ac = 0$$

$$2a^2 - 1 + a(1 - 2a^3) = 0$$

$$2a^2 - 2a^4 + a - 1 = 0$$

$$2a^2(1 - a)(1 + a) + (a - 1) = 0$$

$$\Rightarrow (1 - a)[2a^2(a + 1) - 1] = 0$$

$$\Rightarrow a = 1 \text{ or } 2a^3 + 2a^2 - 1 = 0$$

$$\text{when } a = 1, b = \frac{-1}{a} = -1 \text{ and } c = 1 - 2a^3 = -1$$

$$\text{when } 2a^3 + 2a^2 - 1 = 0$$

There will be only one real solution of

$$f(x) = 2x^3 + 2x^2 - 1 = 0$$

$$\text{as } f(x) = 6x^2 + 4x = 0 \Rightarrow x = 0, \frac{-2}{3}$$

$$f(0), f\left(\frac{-2}{3}\right) < 0$$

\therefore corresponding to this real value of a one triplet is possible

\therefore Exactly two triplets (a, b, c) are possible

83. Let $f(x) = \sin x + (x^3 - 3x^2 + 4x - 2) \cos x$ for $x \in (0, 1)$. Consider the following statements

I. f has a zero in $(0, 1)$

II. f is monotone in $(0, 1)$

Then

(A) I and II are true

(B) I is true and II are false

(C) I is false and II are true

(D) I and II are false

Ans. [A]

Sol. $f(x) = \sin x + (x^3 - 3x^2 + 4x - 2) \cos x, x \in (0, 1)$

$$f(0) = -2 > 0$$

$$f(1) = \sin 1 < 0$$

$$\therefore f(0), f(1) < 0 \Rightarrow f(x) \text{ has a zero in } (0, 1)$$

Now,

$$f(x) = \sin x + [(x - 1)^3 + (x - 1)] \cos x$$

$$\Rightarrow f'(x) = (3(x - 1)^2 + 2) \cos x - \sin x [(x - 1)^3 + (x - 1)]$$

$$= [3(x - 1)^2 + 2] \cos x + [(1 - x)^3 + (1 - x)] \sin x > 0 \quad \forall x \in (0, 1)$$

$$\Rightarrow f(x) \text{ is monotone in } (0, 1)$$

84. Let A be a set consisting of 10 elements. The number of non-empty relations from A to A that are reflexive but not symmetric is
 (A) $2^{89} - 1$ (B) $2^{89} - 2^{45}$ (C) $2^{45} - 1$ (D) $2^{90} - 2^{45}$

Ans. [D]

Sol. $n(A \times A) = 100$

number of (a,a) type pairs is 10

number of (a,b) and (b,a) type pair of pairs is 45 ($a \neq b$)

so, required number of relations is

$$2^{90} - 2^{45}$$

85. In a triangle ABC, the angle bisector BD of $\angle B$ intersects AC in D. Suppose $BC = 2$, $CD = 1$ and $BD = \frac{3}{\sqrt{2}}$.

The perimeter of the triangle ABC is

- (A) $\frac{17}{2}$ (B) $\frac{15}{2}$ (C) $\frac{17}{4}$ (D) $\frac{15}{4}$

Ans. [B]

Sol.

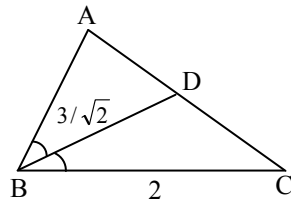

$$\frac{2ac}{a+c} \cos \frac{B}{2} = \frac{3}{\sqrt{2}}$$

$$\Rightarrow \frac{4c}{2+c} \left[\frac{4 + \frac{9}{2} - 1}{2 \times 2 \times \frac{3}{\sqrt{2}}} \right] = \frac{3}{\sqrt{2}}$$

$$\Rightarrow c = 3$$

$$\text{Now, } \frac{c}{a} = \frac{AD}{DC} \Rightarrow AD = \frac{3}{2}$$

$$\Rightarrow b = \frac{5}{2}$$

$$\Rightarrow \text{Perimeter} = \frac{15}{2}$$

86. Let N be the set of natural numbers.

$$\text{For } n \in \mathbb{N}, \text{ define } I_n = \int_0^{\pi} \frac{x \sin^{2n}(x)}{\sin^{2n}(x) + \cos^{2n}(x)} dx.$$

Then for $m, n \in \mathbb{N}$

- (A) $I_m < I_n$ for all $m < n$
 (B) $I_m > I_n$ for all $m < n$
 (C) $I_m = I_n$ for all $m \neq n$
 (D) $I_m < I_n$ for some $m < n$ and $I_m > I_n$ for some $m < n$

Ans. [C]

$$\text{Sol. } I_n = \frac{1}{2} \int_0^{\pi} \left(\frac{x \sin^{2n} x}{\sin^{2n} x + \cos^{2n} x} + \frac{(\pi - x) \sin^{2n} x}{\sin^{2n} x + \cos^{2n} x} \right) dx$$

$$\begin{aligned} &= \frac{\pi}{2} \int_0^{\pi} \frac{\sin^{2n} x dx}{\sin^{2n} x + \cos^{2n} x} \\ &= 2 \times \frac{\pi}{2} \int_0^{\pi/2} \frac{\sin^{2n} x dx}{\sin^{2n} x + \cos^{2n} x} \\ &= \frac{\pi}{2} \int_0^{\pi/2} \frac{\sin^{2n} x + \cos^{2n} x}{\sin^{2n} x + \cos^{2n} x} dx \\ &= \frac{\pi}{2} \times \frac{\pi}{2} = \frac{\pi^2}{4} \\ &\Rightarrow I_m = I_n \forall m, n \end{aligned}$$

87. For $\theta \in [0, \pi]$, let $f(\theta) = \sin(\cos \theta)$ and $g(\theta) = \cos(\sin \theta)$. Let $a = \max_{0 \leq \theta \leq \pi} f(\theta)$, $b = \min_{0 \leq \theta \leq \pi} f(\theta)$, $c = \max_{0 \leq \theta \leq \pi} g(\theta)$ and $d = \min_{0 \leq \theta \leq \pi} g(\theta)$. The correct inequalities satisfied by a, b, c, d are

- (A) $b < d < c < a$ (B) $d < b < a < c$ (C) $b < d < a < c$ (D) $b < a < d < c$

Ans. [C]

Sol.

$$\begin{aligned} f(\theta) &= \sin(\cos \theta) \\ g(\theta) &= \cos(\sin \theta) \\ f(\theta) &= \cos(\cos \theta) \quad (-\sin \theta) < 0 \forall \theta \in [0, \pi] \\ \therefore f(\theta) &\text{ decreases monotonically} \\ \therefore a &= \max f(\theta) = f(0) = \sin 1 \\ b &= \min f(\theta) = f(\pi) = -\sin 1 \\ g'(\theta) &= -\sin(\sin \theta) \cos \theta \\ & \frac{-}{\pi/2} \quad \frac{+}{\pi/2} \\ g(\theta) &= 1 ; g(\pi) = 1 ; g\left(\frac{\pi}{2}\right) = \cos 1 \\ \therefore c &= \max g(\theta) = 1 \\ d &= \min g(\theta) = \cos 1 \\ \therefore b &< d < a < c \end{aligned}$$

88. Six consecutive sides of an equiangular octagon are 6, 9, 8, 7, 10, 5 in that order. The integer nearest to the sum of the remaining two sides is
 (A) 17 (B) 18 (C) 19 (D) 20

Ans. [B]

Sol.

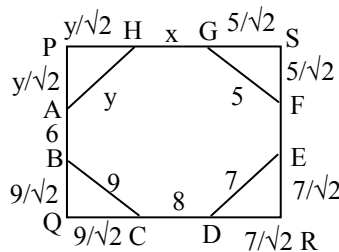

$$\begin{aligned} &\text{Let } ABCDEFGH \text{ be the equiangular octagon as shown } PQ = SR \\ \Rightarrow \frac{y}{\sqrt{2}} + 6 + \frac{9}{\sqrt{2}} &= \frac{5}{\sqrt{2}} + 10 + \frac{7}{\sqrt{2}} \\ \Rightarrow y &= 3 + 4\sqrt{2} \\ \text{Also: } PS &= QR \end{aligned}$$

$$\Rightarrow \frac{y}{\sqrt{2}} + x + \frac{5}{\sqrt{2}} = \frac{9}{\sqrt{2}} + 8 + \frac{7}{\sqrt{2}}$$

$$\Rightarrow x = 4 + 4\sqrt{2}$$

$$\therefore x + y = 7 + 8\sqrt{2} = 18.313$$

\therefore Nearest integer = 18.

89. The value of the integral

$$\int_1^{\sqrt{2}+1} \frac{(x^2-1)}{(x^2+1)} \frac{1}{\sqrt{1+x^4}} dx \text{ is}$$

(A) $\frac{\pi}{6\sqrt{2}}$

(B) $\frac{\pi}{12\sqrt{2}}$

(C) $\frac{\pi}{8\sqrt{2}}$

(D) $\frac{\pi}{4\sqrt{2}}$

Ans. [B]

Sol.
$$\int_1^{\sqrt{2}+1} \frac{(x^2-1)}{\left(x + \frac{1}{x}\right)x\sqrt{x^2 + \frac{1}{x^2}}} dx$$

$$= \int_1^{\sqrt{2}+1} \frac{1 - \frac{1}{x^2}}{x\left(x + \frac{1}{x}\right)\sqrt{\left(x + \frac{1}{x}\right)^2 - 2}} dx$$

Let $x + \frac{1}{x} = \sqrt{2} \sec\theta$

$$\left(1 - \frac{1}{x^2}\right) dx = \sqrt{2} \sec\theta \tan\theta \tan\theta d\theta$$

$$\int_{\pi/4}^{\pi/3} \frac{\sqrt{2} \sec\theta \tan\theta d\theta}{\sqrt{2} \sec\theta \sqrt{2} \tan\theta}$$

$$= \frac{\pi}{12\sqrt{2}}$$

90. Let $a = BC$, $b = CA$, $c = AB$ be the side lengths of a triangle ABC, and m be the length of the median through A. If $a = 8$, $b - c = 2$, $m = 6$ then the nearest integer to b is

(A) 7

(B) 8

(C) 9

(D) 10

Ans. [B]

Sol.
$$m^2 = \frac{2b^2 + 2c^2 - a^2}{4}$$

$$\Rightarrow 144 + 64 = 2[b^2 + (b-2)^2]$$

$$\Rightarrow 104 = 2b^2 - 4b + 4$$

$$\Rightarrow b^2 - 2b - 50 = 0$$

$$\Rightarrow (b-1)^2 = 51$$

$$\Rightarrow b = 1 + \sqrt{51} \in (8, 9)$$

PHYSICS

91. A camera fitted with a polarizer is placed on a mountain, in a manner to record only the reflected image of the sun from the surface of a sea as shown in the figure. If the sun rises at 6.00 AM and sets at 6.00 PM during the summer, then at what time in the afternoon will the recorded image have the lowest intensity, assuming there are no clouds and intensity of the sun at the sea surface is constant throughout the day? (Refractive index of water = 1.33)

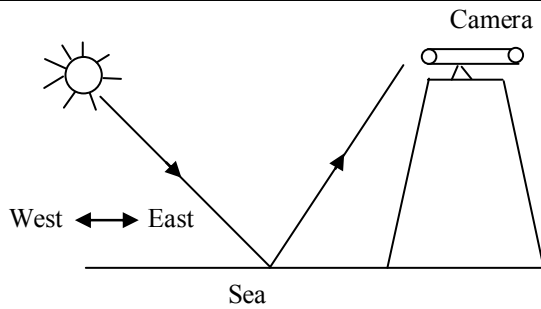

- (A) 12.32 PM (B) 3.32 PM (C) 5.00 PM (D) 6.00 PM

Ans. [B]
Sol.

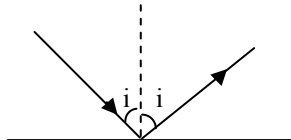

Camera will receive minimum intensity when.
Light will incident at Brewster's angle.

$$\therefore \tan i = \mu = 4/3$$

$$\Rightarrow i = 53^\circ$$

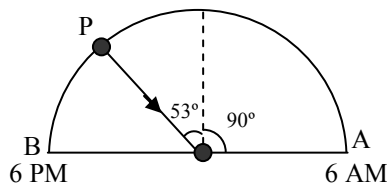

time taken by sun to go from A to P
will be $\frac{12\text{hr}}{180^\circ} \times 143^\circ = 9.53 \text{ hr} = 9 \text{ hr } 32 \text{ min.}$
 $\therefore \text{time} = 6 \text{ AM} + 9\text{hr } 32 \text{ min} \Rightarrow 3:32 \text{ PM}$

92. Suppose a long rectangular loop of width w is moving along the x -direction with its left arm in magnetic field perpendicular to the plane of the loop (see figure). The resistance of the loop is zero and it has an inductance L . At time, $t = 0$, its left arm passes the origin, O .

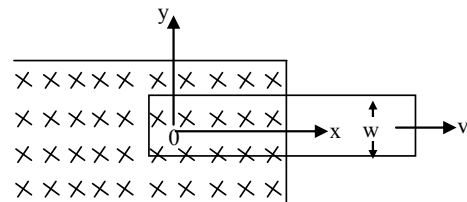

If for $t \geq 0$, the current in the loop is I and the distance of its left arm from the origin is x , then I versus x graph will be

- (A) (B) (C) (D)

Ans. [B]

Sol.

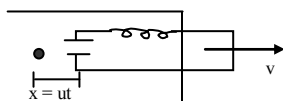

$$VB\ell - \frac{di}{dt}L = 0$$

$$VB\ell = L \frac{di}{dt}$$

$$\Rightarrow \frac{di}{dt} = \frac{VB\ell}{L}$$

= +ve slope

$$x = ut \Rightarrow \frac{dx}{dt} = V$$

$$\frac{di}{dx} = \frac{B\ell}{L} = +ve \text{ slope}$$

93. Imagine a world where free magnetic charges exist. In this world, a circuit is made with a U shape wire and a rod free to slide on it. A current carried by free magnetic charges can flow in the circuit. When the circuit is placed in a uniform electric field, E perpendicular to the plane of the circuit and the rod is pulled to the right with a constant speed v, the "magnetic EMF" in the current and the direction of the corresponding current, arising because of changing electric flux will be (ℓ is the length of the rod and c is speed of light).

(A) $vE\ell$ clockwise

(B) $vE\ell$ counterclockwise

(C) $\frac{vE\ell}{c^2}$ clockwise.

(D) $\frac{vE\ell}{c^2}$ counterclockwise

Ans. [C,D]

Sol.
$$\oint \vec{B} \cdot d\vec{\ell} = \mu_0 \left(I + \epsilon_0 \left(\frac{d\phi_E}{dt} \right) \right)$$

$$\frac{d\phi_E}{dt} = vE\ell$$

$$\therefore \oint \vec{B} \cdot d\vec{\ell} = \mu_0 \epsilon_0 (vE\ell) \Rightarrow \frac{vE\ell}{C^2}$$

Direction of electric field is not given in the question therefore both options are possible.

94. The box in the circuit below has two inputs marked v_+ and v_- and a single output marked v_0 . The output obeys $+10V$ if $v_+ > v_-$

$$v_0 =$$

$$-10v \text{ if } v_+ < v_-$$

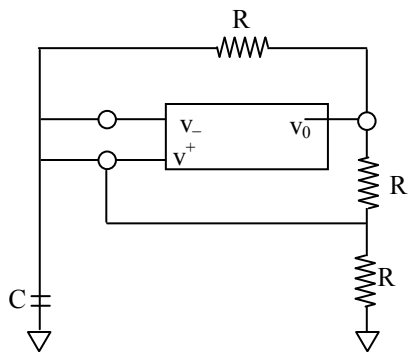

The output v_0 of this circuit a long time after it is switched on is best represented by

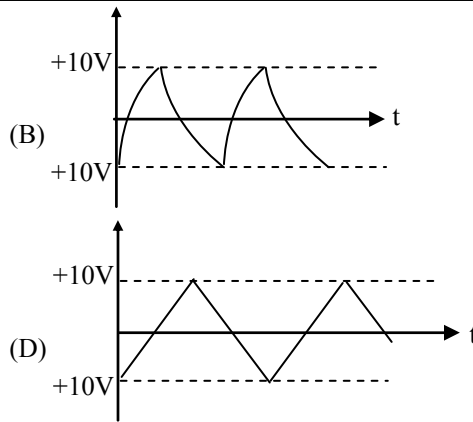
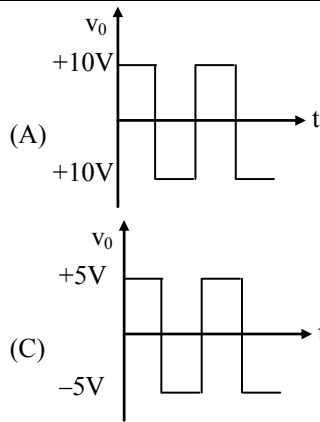

Ans. [A]

Sol. V_0 can only have two values either + 10 or - 10
 \therefore Only (A) is possible

95. A bottle has a thin nozzle on top. It is filled with water, held horizontally at a height of 1m and squeezed slowly by hands so that the water jet coming out of the nozzle hits the ground at a distance of 2m. If the area over which the hands squeeze it is 10cm^2 , the force applied by hands is close to (take $g = 10\text{m/s}^2$ and density of water = 1000kg/m^3)

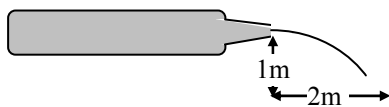

(A) 20 N

(B) 10 N

(C) 5 N

(D) 2.5 N

Ans. [B]



Sol.

Apply Bernoulli between point-1 and point-2.

$$P_1 + \frac{1}{2} \rho V_1^2 = P_2 + \frac{1}{2} \rho V_2^2$$

$$P_1 = P_{\text{atm}} + \frac{\text{force by hand}}{\text{Area}}$$

V_1 tends to zero because area of point-2 is very small.

$$P_2 = P_{\text{atm}}$$

$$P_{\text{atm}} + F/A = P_{\text{atm}} + (1/2) \rho V_2^2 \Rightarrow V_2^2 = \frac{2F}{\rho A}$$

....(i)

From Kinematics.

$$2 = \sqrt{\frac{2(h)}{g}} \times V_2$$

$$\therefore V_2^2 = 20$$

Using (i) & (ii) we get

$$20 \frac{2F}{\rho A} \therefore F = 10\text{N}$$

96. The circular wire in figure below encircles solenoid in which the magnetic flux is increasing at a constant rate out of the plane of the page.

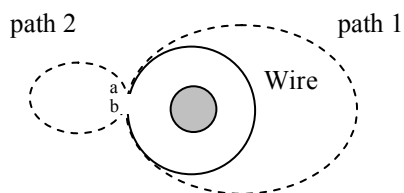

The clockwise emf around the circular loop is ε_0 . By definition a voltmeter measures the voltage difference between the two points given by $V_b - V_a = - \int_a^b \vec{E} \cdot d\vec{s}$. We assume that a and b are infinitesimally close to each other. The values of $V_b - V_a$ along the path 1 and $V_a - V_b$ along the path 2, respectively are
 (A) $-\varepsilon_0, -\varepsilon_0$ (B) $-\varepsilon_0, 0$ (C) $-\varepsilon_0, \varepsilon_0$ (D) $\varepsilon_0, \varepsilon_0$

Ans. [B]

Sol. Flux is increasing while coming out of plane

\therefore Induced electric field will be in clockwise direction.

$\therefore \int_a^b \vec{E} \cdot d\vec{s}$ will be +ve ε_0 .

for path -1

$$V_b - V_a = -\varepsilon_0$$

In path -2 if we see a & b very close and Net emf in path = 0

97. A beam of neutrons performs circular motion of radius, $r = 1$ m under the influence of an inhomogeneous magnetic field with inhomogeneity extending over $\Delta r = 0.01$ m. The speed of the neutrons is 54 m/s. The mass and magnetic moment of the neutrons respectively are 1.67×10^{-27} kg and 9.67×10^{-27} J/T. The average variation of the magnetic field over Δr is approximately.

(A) 0.5 T (B) 1.0 T (C) 5.0 T (D) 10.0 T

Ans. [C]

Sol. $F = M \frac{\partial B}{\partial r} = \frac{mv^2}{r}$

$$\Delta B = \frac{mv^2}{Mr} \Delta r$$

$$= \frac{1.67 \times 10^{-27} \times 54^2 \times 0.01}{9.67 \times 10^{-27} \times 1} = 5.03 \text{ T}$$

98. A student is jogging on a straight path with the speed 5.4 km per hour. Perpendicular to the path is kept a pipe with its opening 8 m from the road (see figure). Diameter of the pipe is 0.45 m. At the other end of the pipe is a speaker emitting sound of 1280 Hz towards the opening of the pipes. As the student passes in front of the pipe, she hears the speaker sound for T seconds. T is in the range (take speed of sound, 320 m/s) :

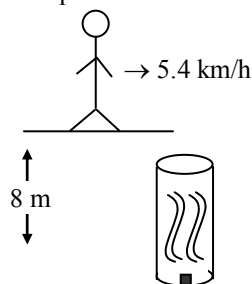

(A) 6 – 12 (B) 12 – 18 (C) 3 – 6 (D) 18 – 12

Ans. [A]

Sol.

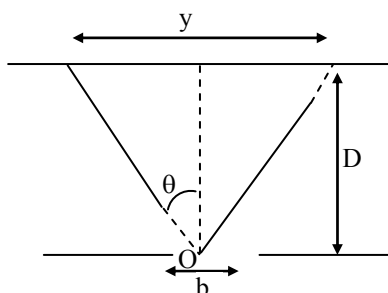

$$\lambda = \frac{320}{1280} = 0.25 \text{ m}$$

Using concept of diffraction of wave

$$b \sin \theta = 1.22 \lambda$$

$$\sin \theta = \frac{25}{45} \times 1.22 = 0.678$$

$$\tan \theta = 0.93$$

$$\tan \theta = \frac{y}{2D}$$

$$y \Rightarrow 2D \tan \theta$$

$$\text{time to cross this region} = \frac{2D \tan \theta}{\text{speed}}$$

$$\Rightarrow \frac{2 \times 8 \times 0.93}{1.5} \approx 9.9 \text{ sec}$$

99. A solar cell is to be fabricated for efficient conversion of solar radiation to emf using material A. The solar cell is to be mechanically protected with the help of a coating using material B. If the band gap energy of materials A and B are E_A and E_B respectively, then which of the following choices is optimum for better performance of the solar cell.

(A) $E_A = 1.5 \text{ eV}, E_B = 5 \text{ eV}$

(B) $E_A = 1.5 \text{ eV}, E_B = 1.5 \text{ eV}$

(C) $E_A = 3 \text{ eV}, E_B = 1.5 \text{ eV}$

(D) $E_A = 0.5 \text{ eV}, E_B = 5 \text{ eV}$

Ans. [A]

Sol. Generally we want the electron to cross energy gaps in material A.

Not in material –B because its just covering. A and E_g in the A should not be very small otherwise there will be huge heat loss because of large difference in E_g and energy of incident photon

100. The "Kangri" is an earthen pot used to stay warm in Kashmir during the winter months. Assume that the "Kangri" is spherical and of surface area $7 \times 10^{-2} \text{ m}^2$. It contains 300 g of a mixture of coal, wood and leaves with calorific value of 30 kJ/g (and provides heat with 10% efficiency). The surface temperature of the 'Kangri' is 60°C and the room temperature is 0°C . Then, a reasonable estimate for the duration t (in hours) that the 'kangri' heat will last is (take the 'kangri' to be a black body) :

(A) 8

(B) 10

(C) 12

(D) 16

Ans. [B]

Sol. $\frac{dQ}{dt} = eA\sigma[T_0^4 - T_s^4]$

$$e = 1, A = 7 \times 10^{-2}, s = 5.67 \times 10^{-8}$$

$$T_0 = 333 \text{ K}, T_s = 273 \text{ K}$$

$$\frac{dQ}{dt} = 26.75 \text{ Watt}$$

$$\text{total energy produced} = \frac{10}{100} \times 30 \times 10^3 \times 5 \times 300$$

$$\Rightarrow 9 \times 10^5 \text{ J}$$

$$\therefore \text{time} = \frac{9 \times 10^5}{26.75 \times 3600} \text{ hrs} = 9.35 \text{ hrs}$$

CHEMISTRY

101. An organic compound Z with molecular formula $C_{11}H_{14}$ gives an optically active compound on hydrogenation. Upon ozonolysis, X produces a mixture of compounds – P and Q. Compound P gives a yellow precipitate when treated with I_2 and NaOH but does not reduce Tollen's reagent. Compound Q does not give any yellow precipitate with I_2 and NaOH but gives Fehling's test. The compound X is

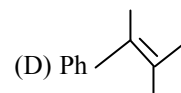
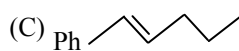
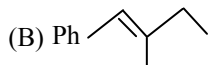
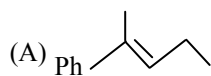

Ans. [A]
Sol.

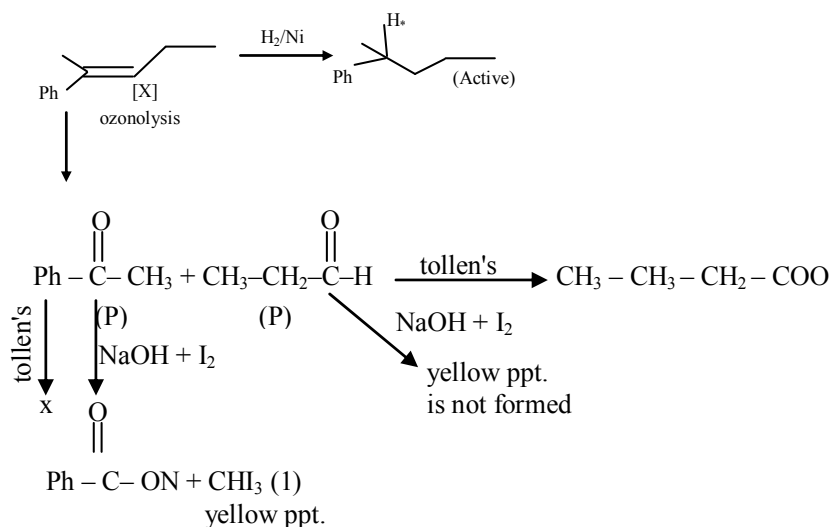

102. The following transformation

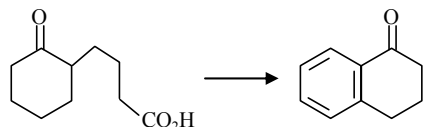

can be carried out in three steps. The reagents required for these three steps in their correct order, are

- (A) (i) NaBH_4 ; (ii) PCl_5 ; (iii) anh. AlCl_3
 (B) (i) SOCl_2 ; (ii) anh. AlCl_3 ; (iii) $\text{Zn}(\text{Hg})/\text{HCl}$
 (C) (i) $\text{Zn}(\text{Hg})/\text{HCl}$; (ii) SOCl_2 ; (iii) anh. AlCl_3
 (D) (i) conc. H_2SO_4 ; (ii) $\text{H}_2\text{N}-\text{NH}_2$, H_2O ;
 (iii) KOH , ethylene glycol, Δ

Ans. [C]

Sol.

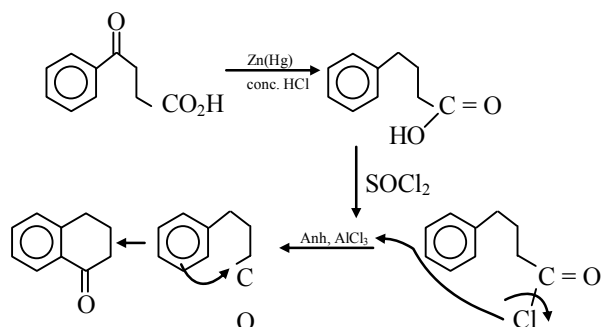

103. In the following reaction

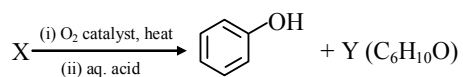

X and Y, respectively are :

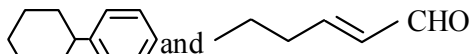
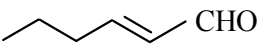
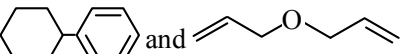
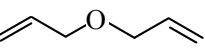
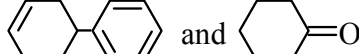
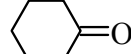
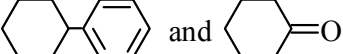
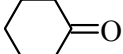
- (A)  and  CHO
- (B)  and 
- (C)  and 
- (D)  and 

Ans. [D]

Sol.

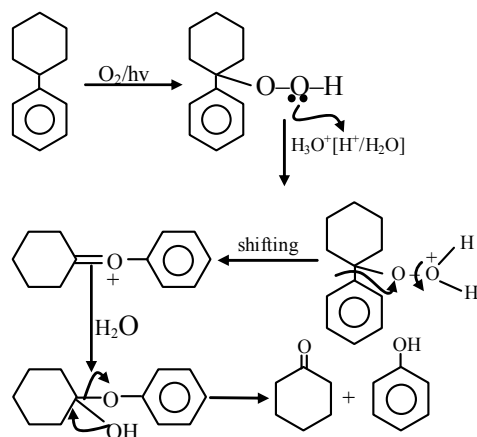

104. A two dimensional solid is made by alternating circles with radius a and b such that the sides of the circles touch. The packing fraction is defined as the ratio of the area under the circles to the area under the rectangle with sides of length x and y .

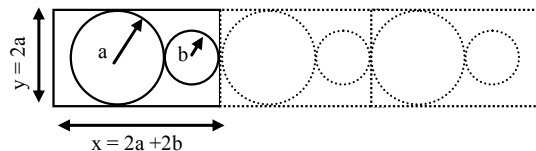
The ratio $r = b/a$ for which the packing fraction is minimized is closest to :

- (A) 0.41 (B) 1.0 (C) 0.50 (D) 0.32

Ans. [A]

Sol.

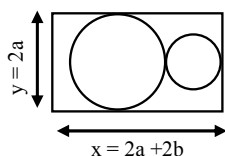

$$\begin{aligned} \text{Area of rectangle} &= xy \\ &= 2a(2a + 2b) \\ &= 4a(a + b) \end{aligned}$$

$$\text{Area covered by circles} = \pi a^2 + \pi b^2 = \pi(a^2 + b^2)$$

$$\text{Packing fraction (P.F.)} = \frac{\pi(a^2 + b^2)}{4(a^2 + ab)}$$

$$= \frac{\pi a^2 \left(1 + \frac{b^2}{a^2}\right)}{4a^2 \left(1 + \frac{b}{a}\right)}$$

$$\text{Putting } r = \left(\frac{b}{a}\right)$$

$$\text{P.F.} = \frac{\pi(1+r^2)}{4(1+r)}$$

$$\text{For minimum P.F., } \frac{d(\text{P.F.})}{dr} = 0$$

$$\text{or } \frac{\pi}{4} \left[\frac{2r(1+r) - (1+r^2)}{(1+r)^2} \right] = 0$$

$$\Rightarrow r^2 + 2r - 1 = 0$$

$$\text{or } r = \frac{-2 + \sqrt{4+4}}{2} = \sqrt{2} - 1 = 0.414$$

Answer is option (A)

105. Consider a reaction that is first order in both directions

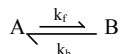

Initially only A is present, and its concentration is A_0 . Assume A_t and A_{eq} are the concentrations of A at time "t" and at equilibrium, respectively. The time "t" at which $A_t = (A_0 + A_{eq})/2$ is :

$$\text{(A) } t = \frac{\ln\left(\frac{3}{2}\right)}{(k_f + k_b)} \quad \text{(B) } t = \frac{\ln\left(\frac{3}{2}\right)}{(k_f - k_b)} \quad \text{(C) } t = \frac{\ln 2}{(k_f + k_b)} \quad \text{(D) } t = \frac{\ln 2}{(k_f - k_b)}$$

Ans. [C]

Sol.



$$t = 0 \quad [A_0] \quad 0$$

$$t = t \quad [A_0] - x \quad x$$

$$= A_t$$

$$t = t_{eq} \quad [A_0] - x_{eq} \quad x_{eq}$$

$$= A_{eq}$$

$$\text{Given at time } t = t \quad A_t = \frac{(A_0 + A_{eq})}{2}$$

$$\text{and } x_{eq} = A_0 - A_{eq}$$

$$\text{Now, } t = \frac{1}{k_f + k_b} \ln \left(\frac{x_e}{x_e - x} \right) = \left(\frac{\ln 2}{k_f + k_b} \right)$$

106. The reaction
 $\text{CaCO}_3(\text{s}) \rightleftharpoons \text{CaO}(\text{s}) + \text{CO}_2(\text{g})$
 is in equilibrium in a closed vessel at 298 K. The partial pressure (in atm) of $\text{CO}_2(\text{g})$ in the reaction vessel is closest to :

[Given : The change in Gibbs energies of formation at 298 K and 1 bar for

$$\text{CaO}(\text{s}) = -603.501 \text{ kJ mol}^{-1}$$

$$\text{CO}_2(\text{g}) = -394.389 \text{ kJ mol}^{-1}$$

$$\text{CaCO}_3(\text{s}) = -1128.79 \text{ kJ mol}^{-1}$$

$$\text{Gas constant } R = 8.314 \text{ J K}^{-1} \text{ mol}^{-1}$$

$$(A) 1.13 \times 10^{-23}$$

$$(B) 0.95$$

$$(C) 1.05$$

$$(D) 8.79 \times 10^{23}$$

Ans. [A]

Sol.



$$\Delta_r G^0 = \Delta_f G^0(\text{CaO}) + \Delta_f G^0(\text{CO}_2) - \Delta_f G^0(\text{CaCO}_3)$$

$$= -603.501 - 394.389 + 1128.79 = 130.9 \text{ kJ mol}^{-1}$$

$$\Delta_r G^0 = -2.303 RT \log K_p$$

$$\log K_p = \frac{130.9 \times 1000}{-2.303 \times 298 \times 8.314} = -22.94$$

$$K_p = \text{antilog}(-22.94) = 1.13 \times 10^{-23}$$

107. A container is divided into two compartments by a removable partition as shown below :

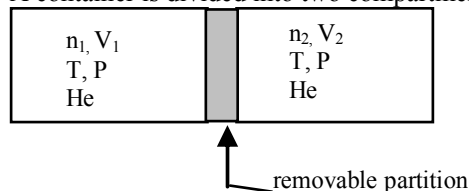

In the first compartment, n_1 moles of ideal gas He is present in a volume V_1 . In the second compartment, n_2 moles of ideal gas He is present in a volume V_2 . The temperature and pressure in both the compartments are T and P , respectively. Assuming R is the gas constant, the total change in entropy upon removing the partition when the gases mix irreversibly is :

$$(A) n_1 R \ln \frac{V_1}{V_1 + V_2} + n_2 R \ln \frac{V_1}{V_1 + V_2}$$

$$(B) n_1 R \ln \frac{V_1 + V_2}{V_1} + n_2 R \ln \frac{V_1 + V_2}{V_1}$$

$$(C) (n_1 + n_2) R \ln \frac{n_1 V_1}{n_2 V_2}$$

$$(D) (n_1 + n_2) R \ln \frac{n_2 V_2}{n_1 V_1}$$

Ans. [B]

Sol. Entropy change $\Delta S = nC_V \ln$

$$\left(\frac{T_2}{T_1} \right) + nR \ln \left(\frac{V_2}{V_1} \right)$$

Since temperature is constant throughout process.

$$\text{He} : \Delta S = n_1 R \ln \left(\frac{V_1 + V_2}{V_1} \right)$$

$$\text{Ne} : \Delta S = n_2 R \ln \left(\frac{V_1 + V_2}{V_2} \right)$$

$$\text{Total change is } (\Delta S) = n_1 R \ln \left(\frac{V_1 + V_2}{V_1} \right)$$

$$+ n_2 R \ln \left(\frac{V_1 + V_2}{V_2} \right)$$

108. Number of stereoisomers possible for the octahedral complexes $[\text{Co}(\text{NH}_3)_3\text{Cl}_3]$ and $[\text{Ni}(\text{en})_2\text{Cl}_2]$, respectively, are :

[en = 1, 2-ethylenediamine]

(A) 2 and 4

(B) 4 and 3

(C) 3 and 2

(D) 2 and 3

Ans. [D]

Sol. $[\text{Co}(\text{NH}_3)_3\text{Cl}_3]$

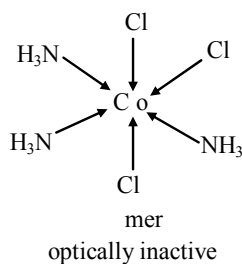
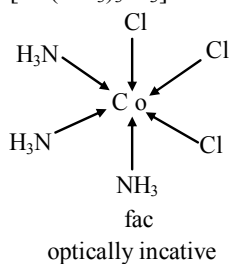

GI = 2

total stereoisomer = 2

$[\text{Ni}(\text{en})_2\text{Cl}_2]$

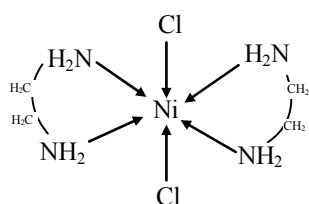
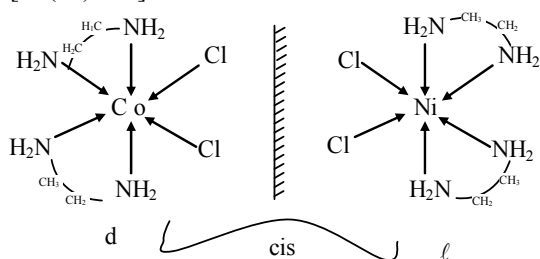

Trans (optically inactive)

G.I. = 2

Optical isomer = 3

stereoisomer = 3

109. When a mixture of NaCl , $\text{K}_2\text{Cr}_2\text{O}_7$ and conc. H_2SO_4 is heated in a dry test tube, a red vapor (X) is evolved. This vapor (X) turns an aqueous solution of NaOH yellow due to the formation of Y. X and Y, respectively, are :

(A) CrCl_3 and $\text{Na}_2\text{Cr}_2\text{O}_7$

(B) CrCl_3 and Na_2CrO_4

(C) CrO_2Cl_2 and Na_2CrO_4

(D) $\text{Cr}_2(\text{SO}_4)_3$ and $\text{Na}_2\text{Cr}_2\text{O}_7$

Ans. [C]

Sol. $4\text{NaCl} + \text{K}_2\text{Cr}_2\text{O}_7 + 6\text{H}_2\text{SO}_4 \rightarrow 4\text{NaHSO}_4 + 2\text{KHSO}_4 + 2\text{CrO}_2\text{Cl}_2(\text{X}) + 6\text{H}_2\text{O}$

$\text{CrO}_2\text{Cl}_2 + 4\text{NaOH} \rightarrow \text{Na}_2\text{CrO}_4(\text{Y}) + 2\text{NaCl} + 2\text{H}_2\text{O}$

X = CrO_2Cl_2

Y = Na_2CrO_4

110. Sodium borohydride upon treatment with idoine produces a Lewis acid (X), which on heating with ammonia produces a cyclic compound (Y) and a colorless gas (Z). X, Y and Z are :
- (A) $X = \text{BH}_3$; $Y = \text{BH}_3 \cdot \text{NH}_3$; $Z = \text{N}_2$
 (B) $X = \text{B}_2\text{H}_6$; $Y = \text{B}_3\text{N}_3\text{H}_6$; $Z = \text{H}_2$
 (C) $X = \text{B}_2\text{H}_6$; $Y = \text{B}_6\text{H}_6$; $Z = \text{H}_2$
 (D) $X = \text{B}_2\text{H}_6$; $Y = \text{B}_3\text{N}_3\text{H}_6$; $Z = \text{N}_2$

Ans. [B]

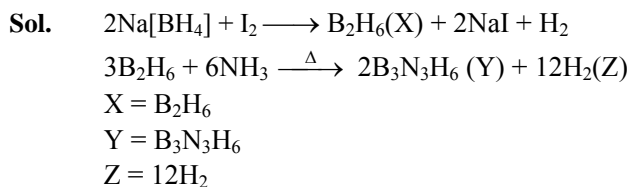

BIOLOGY

111. Which ONE of the following is the most likely ratio of blood groups (A : B : AB) among the progeny from heterozygous parents with B and AB blood groups ?
- (A) 0.5 : 0.25 : 0.25 (B) 0.25 : 0.25 : 0.5
 (C) 0.25 : 0.5 : 0.25 (D) 0 : 0.25 : 0.75

Ans. [C]

Sol.

112. Match the plants in Column I with their features listed in the Column II, III & IV

| Column-I | Column-II | Column-III | Column-iv |
|-----------------|-------------------------|----------------------|-------------------------|
| Types of plants | Types of Photosynthesis | Site of Calvin cycle | Time of stomata opening |
| Rice | CAM | Mesophyll | Day |
| Pineapple | C_4 | Bundle Sheath | Night |
| Sugarcane | C_3 | | |

Choose the Correct combination.

- (A) Rice- C_3 -Mesophyll-Day, Pineapple-CAM-Mesophyll-Night, Sugarcane- C_4 -Bundle sheath-day
 (B) Rice- C_3 -Mesophyll-Day, Pineapple-CAM-Mesophyll-Night, Sugarcane- C_4 -Mesophyll-Day
 (C) Rice- C_4 -Mesophyll-Day, Pineapple- C_3 -Bundle sheath-Night, Sugarcane-CAM-Bundle sheath-Day
 (D) Rice-CAM-Mesophyll-Day, Pineapple-CAM-Mesophyll-Day, Sugarcane- C_4 -Bundle sheath-Day

Ans. [A]

Sol.

113. A bacteriophage T₂ particle contains within its head a double-stranded B-form DNA of molecular weight 1.2×10^8 Da. Assume that the head of a T₂ phage particle is of 210 nm in length and the average molecular weight of a nucleotide is 330 Da. The length of the T₂ genome is in the range of
- (A) 6×10^5 to 6.4×10^5 nm (B) 40×10^4 to 41×10^4 nm
 (C) 1.8×10^5 to 2×10^5 nm (D) 6×10^4 to 6.4×10^4 nm

Ans. [D]

Sol.

114. In the graph below, where N is population size and t is time, M represents

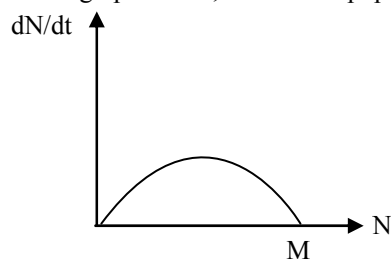

- (A) Specific growth rate .
 (B) Median population size.
 (C) carrying capacity
 (D) minimum population size without going extinct.

Ans. [C]

Sol.

115. Match the metabolic pathways in Column I with their corresponding intermediate molecules listed in Column II

| | Column-I | | Column-II |
|---|--------------------------|------|----------------------------|
| P | Krebs cycle | i. | Dihydroxy acetonephosphate |
| Q | Glycolysis | ii. | Succinate |
| R | Electron transport chain | iii. | Cytochrome c |
| S | Nitrogen fixation | iv. | Glutamate |
| | | v. | Glyoxylate |

Choose the CORRECT combination.

- (A) P-ii, Q-i, R-iii, S-iv
 (B) P-i, Q-v, R-iv, S-ii
 (C) P-v, Q-i, R-iii, S-iv
 (D) P-ii, Q-i, R-iii, S-v

Ans. [A]

Sol.

116. By comparing mitosis and meiosis occurring in the same organism, which ONE of the following options is CORRECT regarding the DNA content per cell ?

- (A) Mitotic anaphase > Meiotic anaphase I = Meiotic anaphase II
 (B) Mitotic anaphase = Meiotic anaphase I > Meiotic anaphase II
 (C) Mitotic anaphase < Meiotic anaphase I = Meiotic anaphase II
 (D) Mitotic anaphase = Meiotic anaphase I < Meiotic anaphase II

Ans. [B]

Sol.

117. Which ONE of the following is likely to occur upon heating a solution of eukaryotic protein from 20°C to 95°C ?

- (A) Breakage of disulphide bonds
 (B) Change in primary structure
 (C) Hydrolysis of peptide bonds
 (D) Change in tertiary structure

Ans. [D]

Sol.

118. Which ONE of the following statements is INCORRECT about the hexokinase-catalysed reaction given below ?
 $\text{Glucose} + \text{ATP} \rightarrow \text{Glucose-6-phosphate} + \text{ADP}$

- (A) This reaction takes place in the cytoplasm
 (B) This is an endergonic reaction
 (C) Folding of hexokinase to fit around the glucose molecule excludes water from the active site
 (D) This reaction involves an induced fit mechanism in hexokinase

Ans. [B]

Sol.

119. An ecologist samples trees in multiple forest plots to determine species richness. Which ONE of the following can help determine the adequacy of sampling effort ?
- (A) Graph the number of new tree species in each successive sampling plot
 - (B) Graph the total number of tree species per total area for all plots combined.
 - (C) Graph the number of individuals per tree species in each successive sampling plot.
 - (D) 30 sampling plots are sufficient, irrespective of the forest area.

Ans. [A]

Sol.

120. In medical diagnostics for a disease, sensitivity (denoted a) of a test refers to the probability that a test result is positive for a person with the disease whereas specificity (denoted b) refers to the probability that a person without the disease test negative. A diagnostic test for influenza has the values of $a = 0.9$ and $b = 0.9$. Assume that the prevalence of influenza in a population is 50% . If a randomly chosen person tests negative, what is the probability that the person actually has influenza ?
- (A) 0.01 (B) 0.02 (C) 0.05 (D) 0.10

Ans. [D]

Sol.