

Part - I

One - Mark Question

MATHEMATICS

1. Let $f(x)$ be a quadratic polynomial with $f(2) = 10$ and $f(-2) = -2$. Then the coefficient of x in $f(x)$ is -
 (A) 1 (B) 2 (C) 3 (D) 4

Ans. (C)

Sol. say $f(x) = ax^2 + bx + c$
 $f(x) = ax^2 + bx + c$
 $f(2) = 4a + 2b + c = 10$
 $f(-2) = 4a - 2b + c = -2$
 $\Rightarrow 4b = 12$
 $b = 3$

2. The square root of $\frac{(0.75)^3}{1-(0.75)} + (0.75 + (0.75)^2 + 1)$ is -

(A) 1 (B) 2 (C) 3 (D) 4

Ans. (B)

Sol. Say 0.75 is x

then $\frac{x^3}{1-x} + (x^2 + x + 1) = P$

$\frac{x^3 - (x-1)(x^2 + x + 1)}{1-x} = P$

$\frac{(x^3 - x^3 + 1)}{1-x} = P \Rightarrow P = \frac{1}{1-x}$

$\Rightarrow P = \frac{1}{1-\frac{3}{4}} = \frac{4}{1}$ $\Rightarrow \sqrt{P} = 2$

3. The sides of a triangle are distinct positive integers in an arithmetic progression. If the smallest side is 10, the number of such triangles is -

(A) 8 (B) 9 (C) 10 (D) Infinitely many

Ans. (B)

Sol.

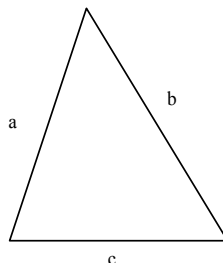

as a, b, c are an AP so $10, 10 + d, 10 + 2d$

sum of $a + b > c$

$20 + d > 10 + 2d$

$10 > d$

As the d is minimum, Hence total possibility of d is 9

4. If a, b, c, d are positive real numbers such that $\frac{a}{3} = \frac{a+b}{4} = \frac{a+b+c}{5} = \frac{a+b+c+d}{6}$, then $\frac{a}{b+2c+3d}$ is -
 (A) $\frac{1}{2}$ (B) 1 (C) 2 (D) Not determinable

Ans. (A)

Sol. $\frac{a}{3} = \frac{a+b}{4} = \frac{a+b+c}{5} = \frac{a+b+c+d}{6} = k$

$$a = 3k, b = k, c = k, d = k$$

$$\text{Hence:- } \frac{a}{b+2c+3d} = \frac{3k}{k+2k+3k} = \frac{1}{2}$$

5. For $\frac{2^2 + 4^2 + 6^2 + \dots + (2n)^2}{1^2 + 3^2 + 5^2 + \dots + (2n-1)^2}$ to exceed 1.01, the maximum value of n is -

- (A) 99 (B) 100 (C) 101 (D) 150

Ans. (D)

Sol.
$$\frac{2^2(1^2 + 2^2 + 3^2 + \dots + n^2)}{[1^2 + 2^2 + 3^2 + \dots + (2n)^2] - 2^2(1^2 + 2^2 + 3^2 + \dots + n^2)}$$

$$\frac{\frac{2^2 n(n+1)(2n+1)}{6}}{\frac{2n(2n+1)(4n+1)}{6} - \frac{2^2 n(n+1)(2n+1)}{6}} > 1.01$$

$$\frac{2n+2}{2n-1} > 1.01$$

$$1 + \frac{3}{2n-1} > 1.01$$

$$2n-1 < 300$$

$$n < 150.5$$

6. In triangle ABC , let AD, BE and CF be the internal angle bisectors with D, E and F on the sides BC, CA and AB respectively. Suppose AD, BE and CF concur at I and B, D, I, F are concyclic, then $\angle IFD$ has measure -
 (A) 15° (B) 30° (C) 45° (D) Any value $\leq 90^\circ$

Ans. (B)

Sol.

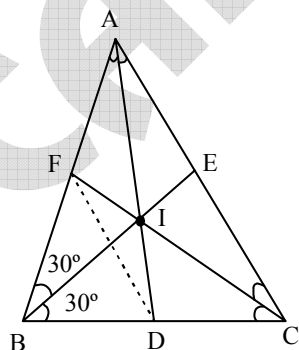

$$\angle AIC = 180^\circ - \left(\frac{A+C}{2} \right)$$

$$= 180^\circ - \left(\frac{A+C}{2} \right)$$

$$= 90 + \frac{B}{2}$$

$$\text{Here } \therefore 90 + \frac{B}{2} + B = 180^\circ$$

$$B = 60^\circ$$

This will be case of equilateral Δ

$$\Rightarrow \angle IFD = 30^\circ$$

7. A regular octagon is formed by cutting congruent isosceles right-angled triangles from the corners of a square. If the square has side-length 1, the side-length of the octagon is -

(A) $\frac{\sqrt{2}-1}{2}$ (B) $\sqrt{2}-1$ (C) $\frac{\sqrt{5}-1}{4}$ (D) $\frac{\sqrt{5}-1}{3}$

Ans. (B)

Sol.

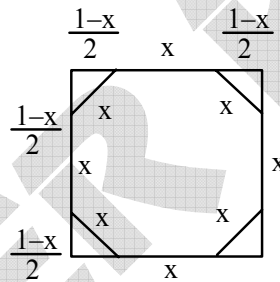

$$\text{Here } 2 \left(\frac{1-x}{2} \right)^2 = x^2$$

$$(1-x)^2 = 2x^2$$

$$x = \sqrt{2}-1$$

8. A circle is drawn in a sector of a larger circle of radius r , as shown in the adjacent figure. The smaller circle is tangent to the two bounding radii and the arc of the sector. The radius of the small circle is -

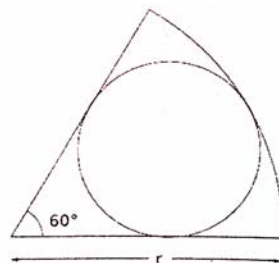

(A) $\frac{r}{2}$ (B) $\frac{r}{3}$ (C) $\frac{2\sqrt{3}r}{5}$ (D) $\frac{r}{\sqrt{2}}$

Ans. (B)

Sol.

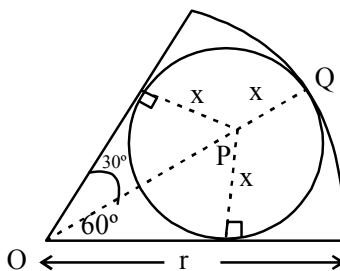

Say the radius of smaller circle is x

Here $OP = x \operatorname{cosec} 30^\circ$

while $OQ = r = x + x \operatorname{cosec} 30^\circ \Rightarrow x = \frac{r}{3}$

9. In the figure AHKF, FKDE and HBCK are unit squares ; AD and BF intersect in X. Then the ratio of the areas of triangles AXF and ABF is -

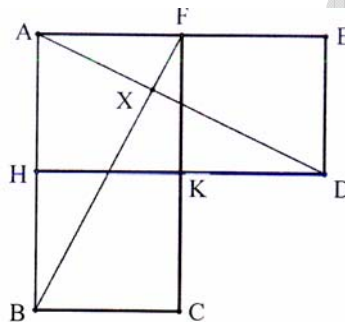

(A) 1/4

(B) 1/5

(C) 1/6

(D) 1/8

Ans. (B)

Sol.

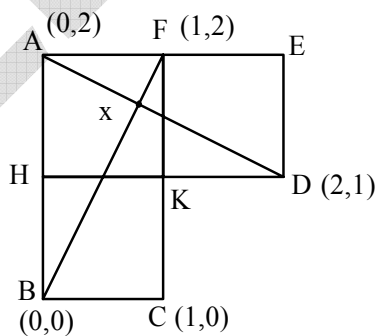

Equation of BF

$$y = 2x$$

equation of AD

$$x + 2y = 4$$

$$x\left(\frac{4}{5}, \frac{8}{5}\right) \Rightarrow \frac{\operatorname{ar}(\triangle AFX)}{\operatorname{ar}(\triangle ABF)} = \frac{\frac{1}{2} \times 1 \times \left(2 - \frac{8}{5}\right)}{\frac{1}{2} \times 1 \times 2} = \frac{1}{5}$$

10. Suppose Q is a point on the circle with centre P and radius 1, as shown in the figure ; R is a point outside the circle such that $QR = 1$ and $\angle QRP = 2^\circ$. Let S be the point where the segment RP intersects the given circle. Then measure of $\angle RQS$ equals -

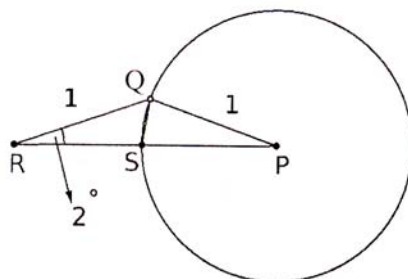

- (A) 86° (B) 87° (C) 88° (D) 89°

Ans. (B)
Sol.

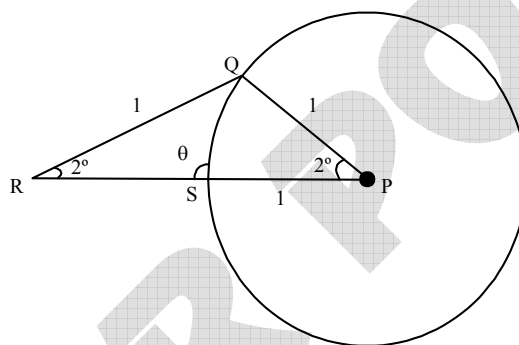

as $PS = PQ$
So $\angle PSQ = \angle PQS = 89^\circ$
 $\therefore \angle RQS = 180^\circ - 2^\circ - 2^\circ - 89^\circ = 87^\circ$

11. Observe that, at any instant, the minute and hour hands of a clock make two angles between them whose sum is 360° . At 6 : 15 the difference between these two angles is -
(A) 165° (B) 170° (C) 175° (D) 180°

Ans. (A)

Sol. We want to find here angle between minute hand and hour hand at 6 : 15

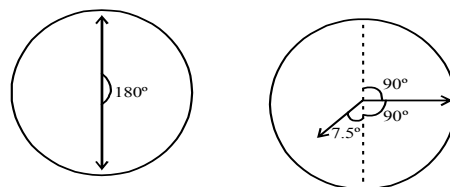

Hour hand covers 30° in 60 minute.
Then in 15 minute it covers $= 7.5^\circ$
So angle between both hand at 6 : 15 is $90^\circ + 7.5 = 97.5^\circ$
Another angle is $360^\circ - 97.5^\circ = 262.5^\circ$
Hence difference is $262.5^\circ - 97.5^\circ = 165^\circ$

12. Two workers A and B are engaged to do a piece of work. Working alone, A takes 8 hours more to complete the work than if both worked together. On the other hand, working alone, B would need $4\frac{1}{2}$ hours more to complete the work than if both worked together. How much time would they take to complete the job working together?
 (A) 4 Hours (B) 5 Hours (C) 6 Hours (D) 7 Hours

Ans. (C)

Sol. If A & B work together take time t hr. If A work alone takes $t + 8$ hr. to complete the work

Work/hr by A is $\frac{1}{t+8}$. Similarly for B work/hr is $\frac{1}{t+9/2}$

When A & B work together there work/hr $\frac{1}{t+8} + \frac{1}{t+9/2}$

Work will be done in t hr.

$$t\left(\frac{1}{t+8} + \frac{1}{t+9/2}\right) = 1$$

By solving

$$t = 6$$

13. When a bucket is half full, the weight of the bucket and the water is 10 kg. When the bucket is two - thirds full, the total weight is 11 kg. What is the total weight, in kg, when the bucket is completely full –
 (A) 12 (B) $12\frac{1}{2}$ (C) $12\frac{2}{3}$ (D) 13

Ans. (D)

Sol. Here weight will be measured in two criteria's weight of bucket w + weight of water ($\pi r^2 h \times \text{density}$) in first case

$$w + \pi r^2 \frac{h}{2} \rho = 10$$

in second case

$$w + \pi r^2 \frac{2}{3} h \rho = 11$$

$$\pi r^2 \left(\frac{2}{3} - \frac{1}{2}\right) h \rho = 1$$

$$\pi r^2 \frac{h}{6} \rho = 1$$

$$\pi r^2 h \rho = 6$$

Also

$$w + \frac{\pi r^2 h \rho}{2} = 10$$

$$w + 3 = 10$$

$$w = 7$$

Hence total weight is

$$w + \pi r^2 h \rho$$

$$= 7 + 6 = 13$$

14. How many ordered pairs of (m, n) integers satisfy $\frac{m}{12} = \frac{12}{n}$?
- (A) 30 (B) 15 (C) 12 (D) 10

Ans. (A)

$$\frac{m}{12} = \frac{12}{n}$$

Sol.

$$mn = 144 \Rightarrow n = \frac{144}{m}$$

We want to find here total number of divisors of 144

$$144 = 2^4 \cdot 3^2$$

Total divisors are $(4 + 1)(2 + 1) = 15$

But negative pairs are also possible hence = 30

15. Let $S = \{1, 2, 3, \dots, 40\}$ and let A be a subset of S such that no two elements in A have their sum divisible by 5. What is the maximum number of elements possible in A ?
- (A) 10 (B) 13 (C) 17 (D) 20

Ans. (C)

Sol. $A = \{1, 2, 6, 7, 11, 12, 16, 17, 21, 22, 26, 27, 31, 32, 36, 37\}$ & One of the element which is multiple of 5

$B = \{3, 4, 8, 9, 13, 14, 18, 19, 23, 24, 28, 29, 33, 34, 38, 39\}$ & One of the element which is multiple of 5

PHYSICS

16. A clay ball of mass m and speed v strikes another metal ball of same mass m , which is at rest. They stick together after collision. The kinetic energy of the system after collision is -
- (A) $mv^2/2$ (B) $mv^2/4$ (C) $2mv^2$ (D) mv^2

Ans. (B)

Sol. Applying the law of conservation of momentum,

$$mv + 0 = (2m)v'$$

$$v' = v/2$$

$$\text{K.E} = \frac{1}{2}(2m)v'^2$$

17. A ball falls vertically downward and bounces off a horizontal floor. The speed of the ball just before reaching the floor (u_1) is equal to the speed just after having contact with the floor (u_2); $u_1 = u_2$. The corresponding magnitudes of accelerations are denoted respectively by a_1 and a_2 . The air resistance during motion is proportional to speed and is not negligible. If g is acceleration due to gravity, then-
- (A) $a_1 < a_2$ (B) $a_1 > a_2$ (C) $a_1 = a_2 \neq g$ (D) $a_1 = a_2 = g$

Ans. (A)

Sol.

Downward motion

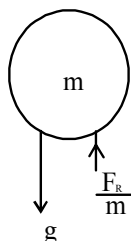

Upward motion

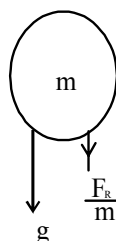

$$\text{Downward- } a_1 = g - \frac{F_R}{m}$$

$$\text{Upward :- } a_2 = g + \frac{F_R}{m}$$

$$a_2 > a_1$$

18. Which of the following statements is true about the flow of electrons in an electric circuit ?

- (A) Electrons always flow from lower to higher potential
- (B) Electrons always flow from higher to lower potential
- (C) Electrons flow from lower to higher potential except through power sources
- (D) Electrons flow from higher to lower potential, except through power sources

Ans. (C)

19. A boat crossing a river moves with a velocity v relative to still water. The river is flowing with a velocity $v/2$ with respect to the bank. The angle with respect to the flow direction with which the boat should move to minimize the drift is -

- (A) 30°
- (B) 60°
- (C) 150°
- (D) 120°

Ans. (D)

Sol.

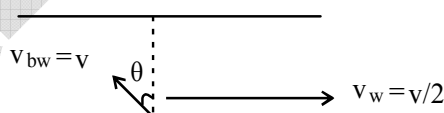

To minimize the drifting

$$\sin \theta = \frac{v_w}{v_{bw}} = \frac{1}{2}$$

$$\theta = 30^\circ$$

$$90^\circ + \theta = 120^\circ$$

20. In the Arctic region hemispherical houses called Igloos are made of ice. It is possible to maintain a temperature inside an Igloo as high as 20°C because -

- (A) Ice has high thermal conductivity (B) Ice has low thermal conductivity
(C) Ice has high specific heat (D) Ice has higher density than water

Ans. (B)

Sol. Ice has low thermal conductivity

21. In the figure below, PQRS denotes the path followed by a ray of light as it travels through three media in succession. The absolute refractive indices of the media are μ_1 , μ_2 and μ_3 respectively. (The line segment RS' in the figure is parallel to PQ).

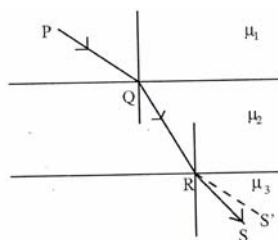

- (A) $\mu_1 > \mu_2 > \mu_3$ (B) $\mu_1 = \mu_3 < \mu_2$ (C) $\mu_1 < \mu_2 < \mu_3$ (D) $\mu_1 < \mu_3 < \mu_2$

Ans. (D)

Sol. $\mu_1 < \mu_3 < \mu_2$

22. A ray of white light is incident on a spherical water drop whose center is C as shown below. When observed from the opposite side, the emergent light -

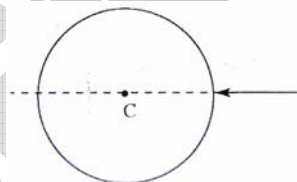

- (A) Will be white and will emerge without deviating
(B) Will be internally reflected
(C) Will split into different colors such that the angles of deviation will be different for all colors
(D) Will split into different colors such that the angles of deviation will be the same for all colors

Ans. (A)

Sol. Perpendicular incidence so no deviation.

23. A convex lens of focal length 15 cm is placed in front of a plane mirror at a distance 25 cm from the mirror. Where on the optical axis and from the centre of the lens should a small object be placed such that the final image coincides with the object ?

- (A) 15 cm and on the opposite side of the mirror
(B) 15 cm and between the mirror and the lens
(C) 7.5 cm and on the opposite side of the mirror
(D) 7.5 cm and between the mirror and the lens

Ans. (A)

Sol.

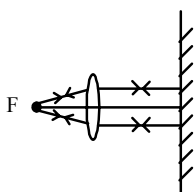

24. Following figures show different combinations of identical bulb(s) connected to identical battery(ies). Which option is correct regarding the total power dissipated in the circuit -

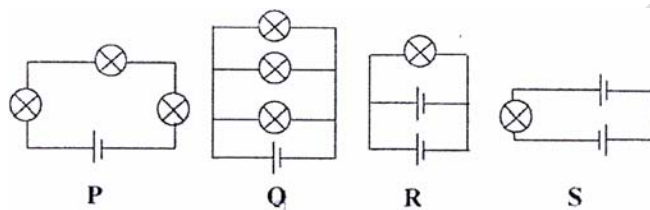

- (A) $P < Q < R < S$ (B) $P < Q < R = S$ (C) $R < Q < P < S$ (D) $P < R < Q < S$

Ans. (D)

Sol. Let R = resistance of each bulb.

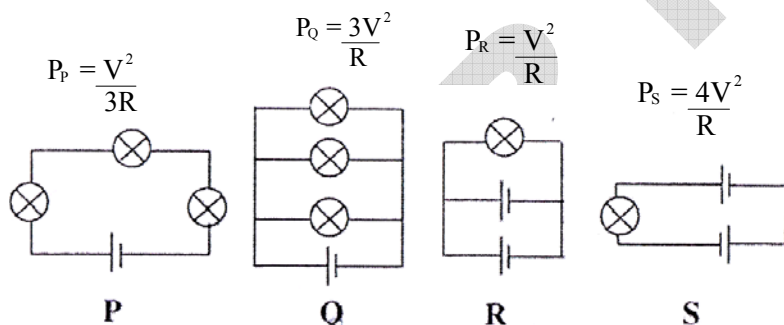

25. A circular metallic ring of radius R has a small gap of width d . The coefficient of thermal expansion of the metal is α in appropriate units. If we increase the temperature of the ring by a amount ΔT , then width of the gap -

- (A) Will increase by an amount $d\alpha\Delta T$
 (B) Will not change
 (C) Will increase by an amount $(2\pi R - d)\alpha\Delta T$
 (D) Will decrease by an amount $d\alpha\Delta T$

Ans. (A)

Sol. Will increase by an amount $d\alpha\Delta T$

26. A girl holds a book of mass m against a vertical wall with a horizontal force F using her finger so that the book does not move. The frictional force on the book by the wall is -
- (A) F and along the finger but pointing towards the girl
 (B) μF upwards where μ is the coefficient of static friction
 (C) mg and upwards
 (D) Equal and opposite to the resultant of F and mg

Ans. (C)

Sol.

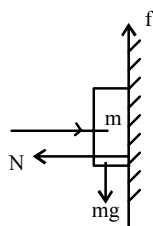

$$\therefore f = mg$$

27. A solid cube and a solid sphere both made of same material are completely submerged in water but to different depths. The sphere and the cube have same surface area. The buoyant force is-
- (A) Greater for the cube than the sphere
 (B) Greater for the sphere than the cube
 (C) Same for the sphere and the cube
 (D) Greater for the object that is submerged deeper

Ans. (B)

Sol. buoyant force $B = V \rho_l g$, $\frac{V_{\text{cube}}}{V_{\text{sphere}}} = \frac{a^3}{\frac{4}{3}\pi R^3}$

but it is given $6a^2 = 4\pi R^2$

$$\text{so, } \frac{V_{\text{cube}}}{V_{\text{sphere}}} = \frac{\sqrt{\pi}}{\sqrt{6}}$$

28. ${}_{92}^{238}\text{U}$ atom disintegrates to ${}_{84}^{214}\text{Po}$ with a half life of 4.5×10^9 years by emitting six alpha particles and n electrons.

Here n is -

- (A) 6 (B) 4 (C) 10 (D) 7

Ans. (B)

Sol. ${}_{92}^{238}\text{U} \rightarrow {}_{84}^{214}\text{Po} + 6\alpha + ne^-$

$$92 = 84 + 12 - n$$

$$n = 4$$

29. Which statements about the Rutherford model of the atom is NOT true ?

- (A) There is a positively charged center in an atom called the nucleus
 (B) Nearly all the mass of an atom resides in the nucleus
 (C) Size of the nucleus is completely to the atom
 (D) Electrons occupy the space surrounding the nucleus

Ans. (C)

Sol. Size of the nucleus is completely to the atom

30. A girl brings a positively charged rod near a thin neutral stream of water from a tap. She observes that the water stream bends towards her. Instead, if she were to bring a negatively charged rod near to the steam, it will—

- (A) Bend in the same direction
 (B) Bend in the opposite direction
 (C) Not bend at all
 (D) Bend in the opposite direction above and below and rod

Ans. (A)

Sol. Due to induction, bend in same direction

CHEMISTRY

31. The weight of calcium oxide formed by burning 20 g of calcium in excess oxygen is –

- (A) 36 g (B) 56 g (C) 28 g (D) 72 g

Ans. (C)

Sol. $\text{Ca} + \frac{1}{2}\text{O}_2 \rightarrow \text{CaO}$

$$\text{Ca} = \frac{20}{40} = \frac{1}{2} \text{ moles}$$

$$\text{CaO formed} = \frac{1}{2} \text{ moles}$$

$$w = \frac{1}{2} \times 56 = 28 \text{ gm}$$

32. The major products in the reaction

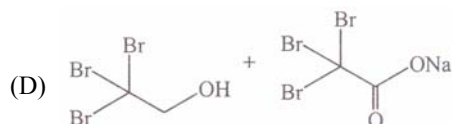
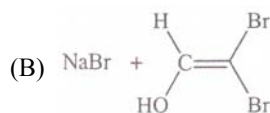
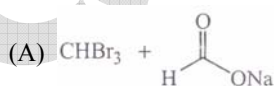

Ans. (A)



33. The number of electrons plus neutrons in ${}^{40}_{19}\text{K}^+$ is -

- (A) 38 (B) 59 (C) 39 (D) 40

Ans. (C)

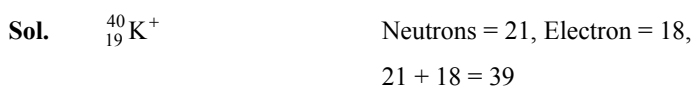

34. Among the following, the most basic oxide is -

- (A) Al_2O_3 (B) SiO_2 (C) P_2O_5 (D) Na_2O

Ans. (D)

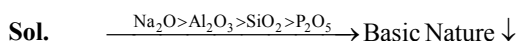

35. By dissolving 0.35 mole of sodium chloride in water, 1.30 L of salt solution is obtained. The molarity of the resulting solution should be reported as -

- (A) 0.3 (B) 0.269 (C) 0.27 (D) 0.2692

Ans. (C)

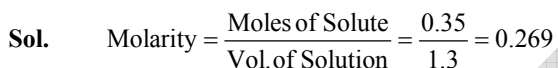

Reported value = 0.27

36. Among the quantities, density (ρ), temperature (T), enthalpy (H), heat capacity (C_p), volume (V) and pressure (P), a set of intensive variables are -

- (A) (ρ , T, H) (B) (H, T, V) (C) (V, T, C_p) (D) (ρ , T, P)

Ans. (D)

37. The value of 'x' in $\text{KAl}(\text{SO}_4)_x \cdot 12\text{H}_2\text{O}$ is -

- (A) 1 (B) 2 (C) 3 (D) 4

Ans. (B)



38. Among the following substituted pyridines, the most basic compound is -

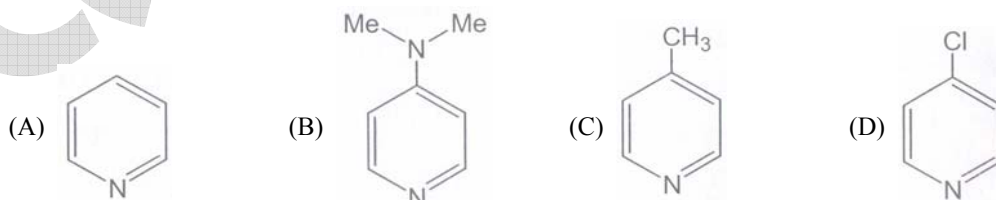

Ans. (B)

39. The major product in the following reaction is -

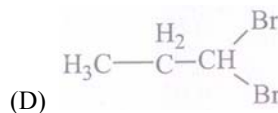
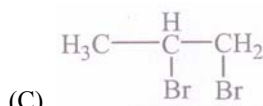
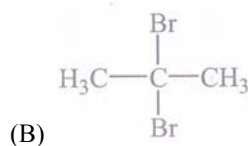
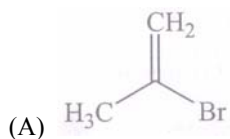

Ans. (B)

Sol. Markownikoff addition

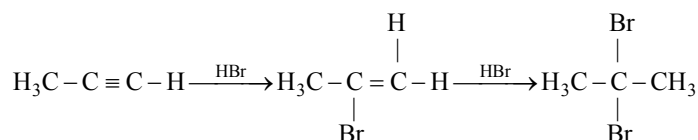

40. The major product in the following reaction at 25° C is -



Ans. (C)

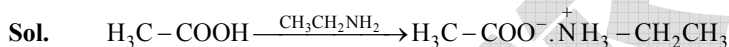

41. A reaction with reaction quotient Q_c and equilibrium constant K_c , will proceed in the direction of the products when -

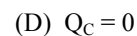

Ans. (B)

Sol. Reaction move in forward direction

42. Acetylsalicylic acid is a pain killer and is commonly known as -

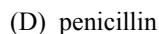
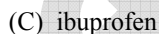
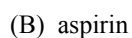
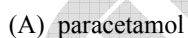

Ans. (B)

43. The molecule which does **not** exhibits strong hydrogen bonding is -

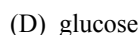
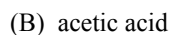

Ans. (C)

44. The following two compounds are -

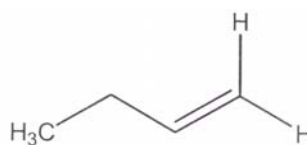
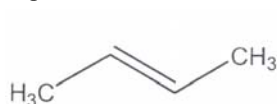

- (A) geometrical isomers
(B) positional isomers
(C) functional group isomers
(D) optical isomers

Ans. (B)

Sol. $\text{H}_3\text{C} - \text{C} = \text{C} - \text{CH}_3$ (But-2-ene), $\text{H}_3\text{C} - \text{CH}_2 - \text{CH} = \text{CH}_2$ (But-1-ene)

45. The graph that does **not** represent the behaviour of an ideal gas is -

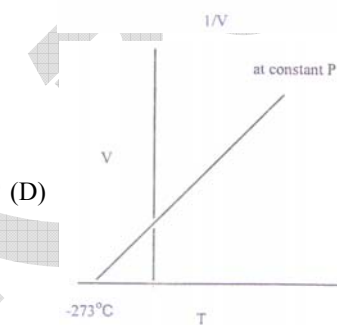
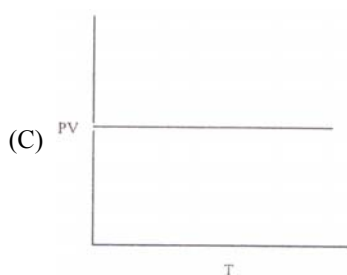
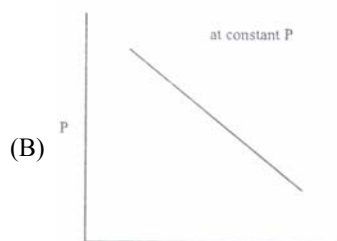
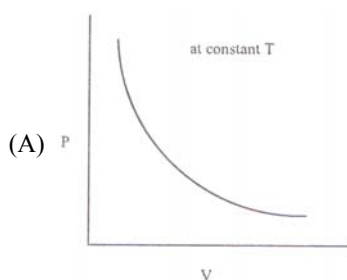

Ans. (B and C)

BIOLOGY

46. A smear of blood from a healthy individual is stained with a nuclear stain called hematoxylin and then observed under a light microscope. Which of the following cell type would be highest in number ?

- (A) neutrophils (B) lymphocytes (C) eosinophils (D) monocytes

Ans. (A)

Sol. Neutrophils the polymorphonuclear neutrophils (PMNs) are the most abundant white blood cells in humans. They account for approximately 50-70% of WBCs

47. Which of the following biological phenomenon involves a bacteriophage ?

- (A) transformation (B) conjugation (C) translocation (D) transduction

Ans. (D)

Sol. Genetic Recombination in bacteria through a virus or bacteriophage is termed as Transduction.

48. In which compartment of a cell does the process of glycolysis takes place ?
(A) golgi complex (B) cytoplasm (C) mitochondria (D) ribosomes
Ans. (B)
Sol. Glycolysis (EMP Pathway) is the common step both in aerobic and anaerobic respiration.
49. Huntington's disease is a disease of the -
(A) nervous system (B) circulatory system (C) respiratory system (D) excretory system
Ans. (A)
Sol. Huntington's disease (HD) is a neurodegenerative genetic disorder to affect muscle coordination and leads to cognitive decline and Psychiatric problems
50. A cell will experience the highest level of endosmosis when it is kept in -
(A) distilled water (B) sugar solution (C) salt solution (D) protein solution
Ans. (A)
Sol. Water moves from hypotonic to hypertonic solution. Distilled water has zero Osmotic Potential.
51. When the leaf of the 'touch-me-not' (chui-mui, Mimosa pudica) plant is touched, the leaf droops because -
(A) a nerve signal passes through the plant (B) the temperature of the plant increases
(C) water is lost from the cells at the base of the leaf (D) the plant dies
Ans. (C)
Sol. Due to change in turgor pressure.
52. If you are seeing mangroves around you, which part of India are you visiting ?
(A) Western Ghats (B) Thar desert (C) Sunderbans (D) Himlayas
Ans. (C)
Sol. Mangrove forests are found in coastal areas.
53. Myeloid tissue is a type of -
(A) haematopoietic tissue (B) cartilage tissue (C) muscular tissue (D) areolar tissue
Ans. (A)
Sol. Myeloid tissue is a biologic tissue with the ability to perform hemotopiesis. It is mainly found as the red bone moved in bone and is after. synonymous with this
54. The heart of an amphibian is usually -
(A) two chambered (B) three chambered
(C) four chambered (D) three and half chambered
Ans. (B)
Sol. The amphibian heart is 3 chambered having 2 auricles + one ventricle

55. Gigantism and acromegaly are due to defects in the function of the following gland –

- (A) adrenals (B) thyroid (C) pancreas (D) pituitary

Ans. (D)

Sol. Acromegaly is syndrome that results when anterior Pituitary gland produces excess growth hormone after epiphyseal plate closure at puberty Gigantism is a condition characterized by excessive growth and height significantly above average. This condition is caused by over production growth hormone in childhood before the long bone epiphyses closed

56. The pH of 10^{-8} M HCl solution is -

- (A) 8 (B) close to 7 (C) 1 (D) 0

Ans. (B)

* It is 6.8 that is near or close to 7.

57. Which one of the following organelles can synthesize some of its own proteins ?

- (A) lysosome (B) golgi apparatus (C) vacuole (D) mitochondrion

Ans. (D)

Sol. Mitochondria is called a semi-autonomous organelle, having its own DNA, RNA and 70 S type of ribosomes, by which it can synthesize some of its proteins.

58. Maltose is a polymer of -

- (A) one glucose and one fructose molecule (B) one glucose and one galactose molecule
(C) two glucose molecules (D) two fructose molecules

Ans. (C)

Sol. Maltose also known as maltobiose or malt sugar, is a disaccharide formed of 2 units of glucose joined with an $\alpha(1 \rightarrow 4)$ glycosidic bond.

59. The roots of some higher plants get associated with a fungal partner. The roots provide food to the fungus while the fungus supplies water to the roots. The structure so formed is known -

- (A) lichen (B) anabaena (C) mycorrhiza (D) rhizobium

Ans. (C)

Sol. Mycorrhiza is symbiotic association between fungal and higher plant root.

60. Prehistoric forms of life are found in fossils. The probability of finding fossils of more complex organisms –

- (A) increases from lower to upper strats (B) decreases from lower to upper strata
(C) remains constant in each stratum (D) uncertain

Ans. (A)

Sol. During the course of evolution simple organisms evolved first while complex organisms evolved later. Fossilization of complex organisms took later in upper strata of earth crust.

Part – 2

Two - Mark Question

MATHEMATICS

61. Let a, b, c be positive integers such that $\frac{a\sqrt{2}+b}{b\sqrt{2}+c}$ is a rational number, then which of the following is always an integer ?

(A) $\frac{2a^2+b^2}{2b^2+c^2}$

(B) $\frac{a^2+2b^2}{b^2+2c^2}$

(C) $\frac{a^2+b^2-c^2}{a+b-c}$

(D) $\frac{a^2+b^2+c^2}{a+c-b}$

Ans. (D)

Sol. $\left(\frac{a\sqrt{2}+b}{b\sqrt{2}+c}\right)\left(\frac{b\sqrt{2}-c}{b\sqrt{2}-c}\right) = \frac{2ab - \sqrt{2}ac + \sqrt{2}b^2 - bc}{2b^2 - c^2} = \frac{b(2a-c) + \sqrt{2}(b^2-ac)}{2b^2 - c^2}$

Is rational when $b^2 = ac$ i.e. a, b, c are in GP

Here given option (A), (B), (C) does not satisfy the criteria

But option (D) always satisfy

62. The number of solutions (x, y, z) to the system of equations

$$x + 2y + 4z = 9, 4yz + 2xz + xy = 13, xyz = 3$$

Such that at least two of x, y, z are integers is -

(A) 3

(B) 5

(C) 6

(D) 4

Ans. (B)

Sol. $x + 2y + 4z = 9$;

$2xy + 8yz + 4xz = 26$;

$(x)(2y)(4z) = 24$

Say roots of $P^3 - 9P^2 + 26P - 24 = 0$ are $x, 2y$ and $4z$

Here $(P-2)(P^2-7P+12) = 0$

$(P-2)(P-3)(P-4) = 0$

now $4z = 4$; $2y = 2$; $x = 3$ then $(3, 1, 1)$

$x = 2$; $2y = 4$; $4z = 3$ then $\left(2, 2, \frac{3}{4}\right)$

$x = 3$; $2y = 4$; $4z = 2$ then $\left(3, 2, \frac{1}{2}\right)$

$x = 2$; $2y = 3$; $4z = 4$ then $\left(2, \frac{3}{2}, 1\right)$

$x = 4$; $2y = 2$; $4z = 3$ then $\left(4, 1, \frac{3}{4}\right)$

Hence there are five solutions.

63. In a triangle ABC, it is known that $AB = AC$. Suppose D is the mid-point of AC and $BD = BC = 2$. Then the area of the triangle ABC is -

(A) 2 (B) $2\sqrt{2}$ (C) $\sqrt{7}$ (D) $2\sqrt{7}$

Ans. (C)

Sol.

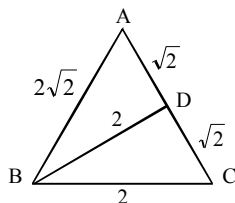

We know

$$AB^2 + BC^2 = 2(CD^2 + BD^2)$$

$$AB^2 + 4 = 2\left(\frac{AB^2}{4} + 4\right)$$

$$AB^2 + 4 = \frac{AB^2}{2} + 8$$

$$\frac{AB^2}{2} = 4$$

$$AB^2 = 8$$

$$AB = 2\sqrt{2}$$

Now

$$\text{Area} = \frac{1}{2} \times 2 \times \sqrt{7} = \sqrt{7} \text{ square unit.}$$

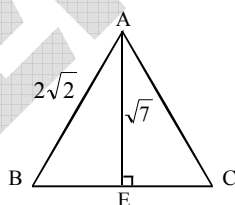

64. A train leaves Pune at 7 : 30 am and reaches Mumbai at 11 : 30 am. Another train leaves Mumbai at 9 : 30 am and reaches Pune at 1 : 00 pm. Assuming that the two trains travel at constant speeds, at what time do the two trains cross each other -

(A) 10 : 20 am (B) 11 : 30 am (C) 10 : 26 am (D) Data not sufficient

Ans. (B)

Sol. First train from Pune to Mumbai takes 4hrs.

Second train from Mumbai to Pune takes 3.5hrs.

$$\text{Speed of train from Pune to Mumbai is } V_1 = \frac{d}{4}$$

$$\text{Speed of train from Mumbai to Pune is } V_2 = \frac{d}{3.5}$$

$$\text{Distance traveled by first train till 9:30 is } x = \frac{d}{4} \times 2 = \frac{d}{2}$$

Say now both trains meet after time from 9:30

$$\frac{x}{d/4} = \frac{\frac{d}{2} - x}{3.5} \Rightarrow \frac{4x}{d} = \frac{3.5}{2} - \frac{3.5x}{d} \Rightarrow \frac{7.5x}{d} = \frac{3.5}{2} \Rightarrow 15x = 3.5d \Rightarrow 30x = 7d$$

time taken by first train from 9:30 is $\frac{4x}{d} = 4\left(\frac{7}{30}\right)$

$$= \frac{14}{15}$$

$$= 56 \text{ min}$$

Then both train meet at 9.30 + 56 min = 10 : 26 am

65. In the adjacent figures, which has the shortest path -

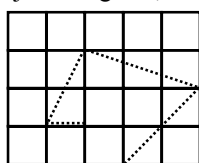

Fig.1

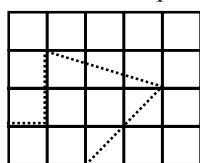

Fig.2

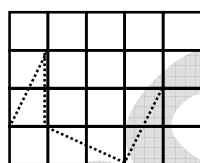

Fig.3

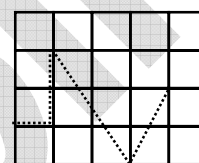

Fig.4

(A) Fig 1

(B) Fig 2

(C) Fig 3

(D) Fig 4

Ans.

(C)

Sol.

For Fig 1

A(2, 1); B(1,1); C(2,3); D(5,2); E(3,0)

$$AB = 1, BC = \sqrt{5}, CD = \sqrt{10}, DE = \sqrt{8}$$

$$AB + BC + CD + DE = 9.22$$

For Fig 2

A(0, 1), B(1, 1), C(1, 3), D(4, 2), E(2, 0)

$$AB = 1, BC = 2, CD = \sqrt{10}, DE = \sqrt{8}$$

$$AB + BC + CD + DE = 8.99$$

For Fig 3

A(0, 1), B(1, 3), C(1, 1), D(3, 0), E(4, 2)

$$AB = \sqrt{5}; CD = \sqrt{5}; DE = \sqrt{5}; BC = 2$$

$$AB + BC + CD + DE = 8.69$$

For Fig 4

A(0, 1), B(1, 1), C(1, 3), D(3, 0), E(4, 2)

$$AB = 1, BC = 2, CD = \sqrt{13}, DE = \sqrt{5}$$

$$AB + BC + CD + DE = 8.841$$

PHYSICS

66. In the circuit shown, n identical resistors R are connected in parallel ($n > 1$) and the combination is connected in series to another resistor R_0 . In the adjoining circuit n resistors of resistance R are all connected in series along with R_0 -

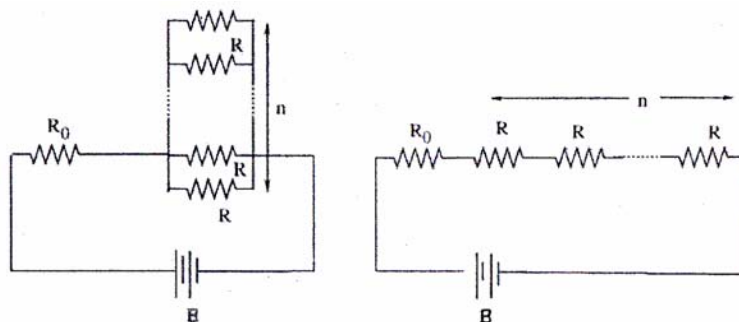

The batteries in both circuits are identical and net power dissipated in the n resistors in both circuits is same. The ratio R_0/R is

- (A) 1 (B) n (C) n^2 (D) $1/n$

Ans. (A)

Sol. $i_1 = \frac{nE}{nR_0 + R}$, $i_2 = \frac{E}{(R_0 + nR)}$

$$P_1 = \frac{nE^2 R}{(nR_0 + R)^2}, P_2 = \frac{nE^2 R}{(R_0 + nR)^2}$$

$$\therefore P_1 = P_2$$

$$\text{Hence } R_0/R = 1$$

67. A firecracker is thrown with velocity of 30 ms^{-1} in a direction which makes an angle of 75° with the vertical axis. At some point on its trajectory, the firecracker splits into two identical pieces in such a way that one piece fall 27 m far from the shooting point. Assuming that all trajectories are contained in the same plane, how far will the other piece fall from the shooting point? (Take $g = 10 \text{ ms}^{-2}$ and neglect air resistance)–

- (A) 63 m or 144 m (B) 72 m or 9 m (C) 28 m or 72 m (D) 63 m or 117 m

Ans. (D)

Sol.

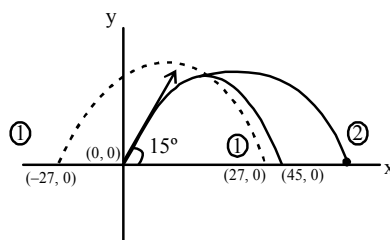

Under influence of constant force centre of mass follows its original path

$$R = \frac{30 \times 30 \times \frac{1}{2}}{10} = 45 \text{ m} \Rightarrow 45 = \frac{\pm m \times 27 + mx}{m + m} \Rightarrow x = 63 \text{ m}, 117 \text{ m}$$

68. A block of mass m is sliding down an inclined plane with constant speed. At a certain instant t_0 , its height above the ground is h . The coefficient of kinetic friction between the block and the plane is μ . If the block reaches the ground at a later instant t_g , then the energy dissipated by friction in the time interval $(t_g - t_0)$ is -

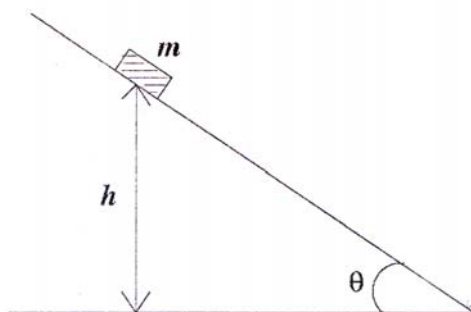

- (A) μmgh (B) $\mu mgh/\sin \theta$ (C) mgh (D) $\mu mgh/\cos \theta$

Ans. (C)

Sol. $W_f + W_{mg} = \Delta K.E.$, ($\Delta K.E. = 0$)

$$W_f = -W_{mg}$$

$$W_f = -mgh$$

$$\therefore \text{Energy dissipated} = mgh$$

69. A circular loop of wire is in the same plane as an infinitely long wire carrying a constant current i . Four possible motions of the loop are marked by N, E, W, and S as shown -

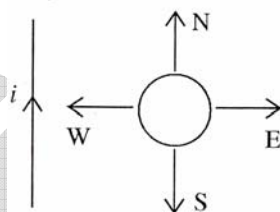

A clockwise current is induced in the loop when loop is pulled towards -

- (A) N (B) E (C) W (D) S

Ans. (B)

Sol. This is in accordance with Lenz's law

70. 150 g of ice is mixed with 100 g of water at temperature 80°C . The latent heat of ice is 80 cal/g and the specific heat of water is $1 \text{ cal/g-}^\circ\text{C}$. Assuming no heat loss to the environment, the amount of ice which does **not** melt is -
- (A) 100 g (B) 0 g (C) 150 g (D) 50 g

Ans. (D)

Sol. Heat loss by water = heat gain by ice.

$$100 \times 1 \times 80 = m \times 80$$

$$m = 100 \text{ gm ice melt}$$

$$\therefore \text{Remaining ice} = 50 \text{ g}$$

CHEMISTRY

71. Upon fully dissolving 2.0 g of a metal in sulfuric acid, 6.8 g of the metal sulfate is formed. The equivalent weight of the metal is -
 (A) 13.6 g (B) 20.0 g (C) 4.0 g (D) 10.0 g

Ans. (B)

Sol. Equivalents of metal = Equivalents of metal sulphate

$$\frac{\text{wt. of metal}}{\text{Eq. wt. of metal}} = \frac{\text{wt. of metal sulphate}}{\text{Eq. wt. metal sulphate}}$$

$$\frac{2}{x} = \frac{6.8}{x + 48}$$

$$6.8x = 2x + 96$$

$$4.8x = 96$$

$$x = \frac{96}{4.8} = 20$$

72. Upon mixing equal volumes of aqueous solutions of 0.1 M HCl and 0.2 M H₂SO₄, the concentration of H⁺ in the resulting solution is -
 (A) 0.30 mol/L (B) 0.25 mol/L (C) 0.15 mol/L (D) 0.10 mol/L

Ans. (B)

Sol.

0.1M HCl, V volume

H⁺ moles = 0.1V

0.2M H₂SO₄, V volume

H⁺ moles = 0.2 × 2 × V = 0.4V

Total moles of H⁺ = 0.4V + 0.1V = 0.5V

$$[\text{H}^+] = \frac{\text{Moles}}{\text{Vol.}} = \frac{0.5V}{2V} = 0.25 \text{ M / L}$$

73. The products X and Y in the following reaction sequence are -

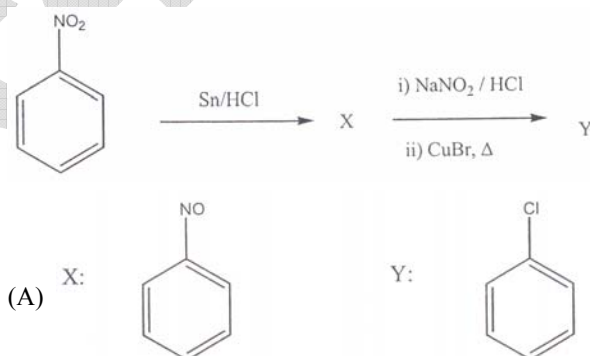

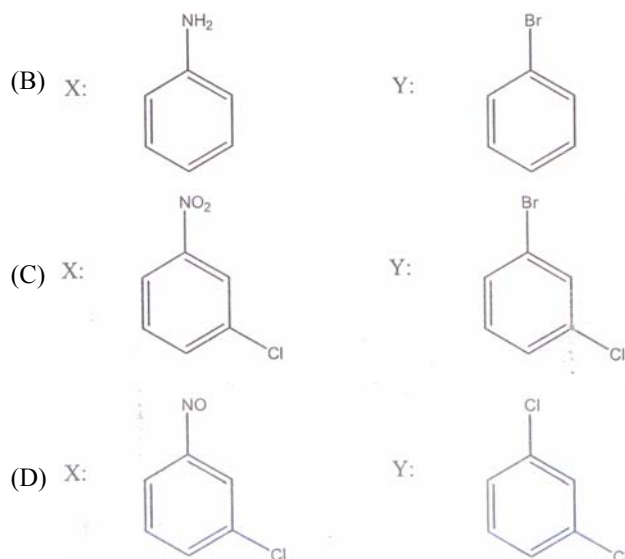

Ans. (B)
Sol.

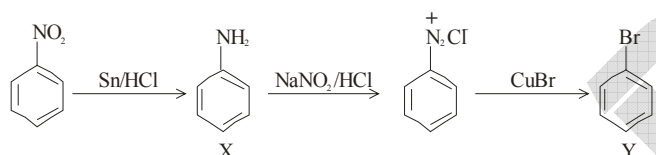

74. A plot of the kinetic energy ($\frac{1}{2}mv^2$) of ejected electrons as a function of the frequency (ν) of incident radiation for four alkali metals (M_1, M_2, M_3, M_4) is shown below.
The alkali metals M_1, M_2, M_3 and M_4 are, respectively -

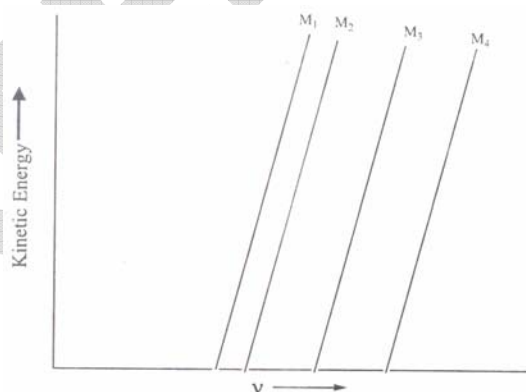

- (A) Li, Na, K, and Rb
(B) Rb, K, Na, and Li
(C) Na, K, Li, and Rb
(D) Rb, Li, Na, and K

Ans. (B)

Sol. $\xrightarrow{\text{Rb, K, Na, Li}} \text{I.P.} \downarrow$

75. The number of moles of Br_2 produced when two moles of potassium permanganate are treated with excess potassium bromide in aqueous acid medium is -
(A) 1 (B) 3 (C) 2 (D) 4

Ans. (Bonus)

* Because answer is not matching with balanced reaction

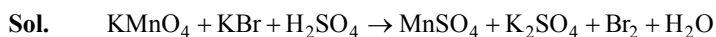

Balanced equations

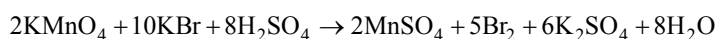

Eq. of $\text{KMnO}_4 = \text{Eq. of Br}_2$

Mole \times n = Mole \times n

$$2 \times 5 = \text{Mole} \times 2$$

5 moles of Br_2 are formed

BIOLOGY

76. A baby is born with the normal number and distribution of rods, but no cones in his eyes. We would expect that the baby would be -
(A) colour blind (B) night blind
(C) blind in both eyes (D) blind in one eye

Ans. (A)

Sol. Absence of cone cells in eyes is known as total colour blindness or monochromacy. This person views everything as if it were an a black and white television. Monochromacy occurs when 2 or all 3 of cone pigments are missing and color and lightness vision is reduced to one dimension.

77. In mammals, pleural membranes cover the lungs as well as insides of the rib cage. The pleural fluid in between the two membranes -
(A) dissolves oxygen for transfer to the alveoli
(B) dissolves CO_2 for transfer to the blood
(C) provides partial pressure
(D) reduces the friction between the ribs and the lungs

Ans. (D)

Sol. Pleural fluid is a serous fluid produced by normal pleural. Pleural fluid allows the pleural to slide effortlessly against each other during ventilation.

78. At which phase of the cell cycle, DNA polymerase activity is at its highest ?
(A) Gap 1 (G1) (B) Mitotic (M)
(C) Synthetic (S) (D) Gap 2 (G2)

Ans. (C)

Sol. S-phase or synthetic phase is significant due to DNA synthesis. DNA synthesis is aided by the enzyme DNA polymerases. Synthesis of DNA polymerase occur in G_1 phase but it become active only in S phase of cell cycle.



79. Usain Bolt, an Olympic runner, at the end of a 100 meter sprint, will have more of which of the following in his muscles ?

- (A) ATP (B) Pyruvic acid
(C) Lactic acid (D) Carbon dioxide

Ans. (C)

Sol. A 100 meter sprint takes less than 10 sec. to complete. During this very short period the major driving forces are stored high energy phosphates and anaerobic glycolysis which produces lactic acid.

80. Desert temperature often varies between 0 to 50°C. The DNA polymerase isolated from a camel living in the desert will be able to synthesize DNA most efficiently at –

- (A) 0° C (B) 37° C
(C) 50° C (D) 25° C

Ans. (B)

Sol. The optimum temperature for DNA polymerase is 37 degree Celcius.