



CAREER POINT

KV PY QUESTION PAPER-2016 (STREAM SX)

Part – I

One - Mark Questions

Date : 06 / 11 / 2016

MATHEMATICS

1. The number of triples (x, y, z) of real numbers satisfying the equation $x^4 + y^4 + z^4 + 1 = 4xyz$ is

(A) 0 (B) 4 (C) 8 (D) more than 8

Ans. [B]

Sol. (x, y, z) are real & x^4, y^4, z^4 are positive real numbers

$$\therefore \frac{x^4 + y^4 + z^4 + 1}{4} \geq |xyz|$$

$$\Rightarrow (xyz) \geq |xyz|$$

$$\text{i.e., } xyz > 0$$

So it holds equality

$$\therefore x^4 = y^4 = z^4 = 1 ; \text{ But } xyz > 0$$

$$\therefore (x, y, z) \in \{(1, 1, 1), (1, -1, -1), (-1, 1, -1), (-1, -1, 1)\}$$

So no. of triplets is 4.

2. If $P(x)$ be a polynomial with real coefficients such that $P(\sin^2 x) = P(\cos^2 x)$, for all $x \in [0, \pi/2]$. Consider the following statements :

I. $P(x)$ is an even function.

II. $P(x)$ can be expressed as a polynomial in $(2x - 1)^2$

III. $P(x)$ is a polynomial of even degree

Then.

(A) all are false

(B) only I and II are true

(C) only II and III are true

(D) all are true

Ans. [C]

Sol. $P(\sin^2 x) = P(\cos^2 x)$

$$P(\sin^2 x) = P(1 - \sin^2 x)$$

$$P(x) = P(1 - x) \quad \forall x \in [0, 1]$$

Differentiable both sides w.r.t. x

$$P'(x) = -P'(1 - x)$$

$$\text{So } P'(x) \text{ is symmetric about point } x = \frac{1}{2}$$

So $P'(x)$ has highest degree odd

$\Rightarrow P(x)$ has highest degree even

3. For any real number r , let $A_r = \{e^{i\pi r n} : n \text{ is a natural number}\}$ be a set of complex numbers. Then -
- (A) $A_1, A_{\frac{1}{\pi}}, A_{0.3}$ are all infinite sets
 (B) A_1 is a finite set and $A_{\frac{1}{\pi}}, A_{0.3}$ are infinite sets
 (C) $A_1, A_{\frac{1}{\pi}}, A_{0.3}$ are all finite sets
 (D) $A_1, A_{0.3}$ are finite sets and $A_{\frac{1}{\pi}}$ is an infinite sets

Ans. [D]

Sol. $e^{i\pi r n}$ is always a finite set when r is a rational & is infinite when $r = \frac{1}{\pi}$.

4. Number of integers k for which the equation $x^3 - 27x + k = 0$ has at least two distinct integer roots is -
- (A) 1
 (B) 2
 (C) 3
 (D) 4

Ans. [B]

Sol. Let $f(x) = x^3 - 27x$
 $f'(x) = 3x^2 - 27 = 3(x^2 - 9)$

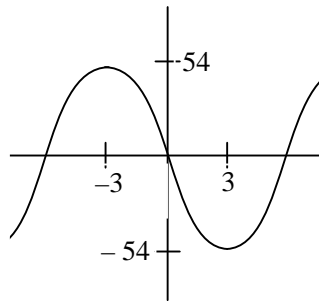

As sum of the roots is zero, so if two roots are integer then 3rd root has to be integer

Now put $x = 6t$

$$216t^3 - 27 \times 6t + k = 0$$

$$54(4t^3 - 3t) + k = 0$$

Put $t = \cos \theta$

$$54 \cos 3\theta = -k$$

Now for $3\theta = 0, 2\pi$ we get integral solution

So two values of 'k'

5. Suppose the tangent to the parabola $y = x^2 + px + q$ at $(0, 3)$ has slope -1 . Then $p + q$ equals
- (A) 0
 (B) 1
 (C) 2
 (D) 3

Ans. [C]

Sol. $(0, 3)$ lies on the curve

So $q = 3$

$$\text{Now } \frac{dy}{dx} = 2x + p; \left(\frac{dy}{dx} \right)_{(0,3)} = p = -1$$

$$\therefore p + q = -1 + 3 = 2$$

6. Let $O = (0, 0)$; let A and B be points respectively on x -axis and y -axis such that $\angle OBA = 60^\circ$. Let D be a point in the first quadrant such that OAD is an equilateral triangle. Then the slope of DB is -
- (A) $\sqrt{3}$
 (B) $\sqrt{2}$
 (C) $\frac{1}{\sqrt{2}}$
 (D) $\frac{1}{\sqrt{3}}$

Ans. [D]

Sol.

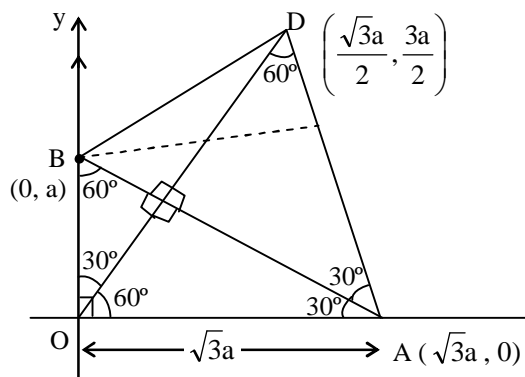

$$M_{BD} = \frac{1}{\sqrt{3}}$$

7. Suppose the parabola $(y - k)^2 = 4(x - h)$, with vertex A, passes through $O = (0, 0)$ and $L = (0, 2)$. Let D be an end point of the latus rectum. Let the y-axis intersect the axis of the parabola at P. Then $\angle PDA$ is equal to

- (A) $\tan^{-1} \frac{1}{19}$ (B) $\tan^{-1} \frac{2}{19}$ (C) $\tan^{-1} \frac{4}{19}$ (D) $\tan^{-1} \frac{8}{19}$

Ans. [B]
Sol.

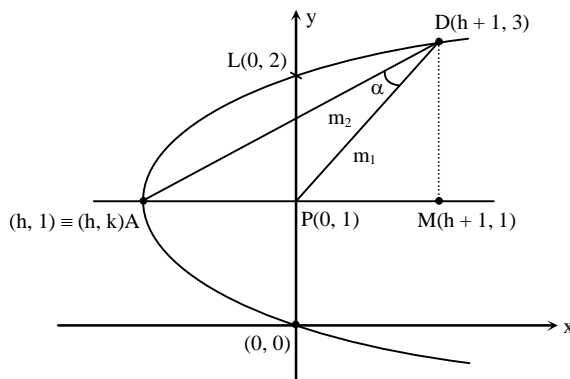

Curve, $S : (y - k)^2 = 4(x - h)$

LLR = 4 ; Clearly $k = 1$; $\Rightarrow A(h, 1)$ & 'M' is focus $(h + 1, 1)$

So $D(h + 1, 3)$

$S_{(0,0)} = 0 \Rightarrow k^2 = -4h$

$$\Rightarrow h = \frac{-1}{4} \qquad \Rightarrow D\left(\frac{3}{4}, 3\right)$$

$$\text{Now ; } \tan \alpha = \frac{|m_1 - m_2|}{|1 + m_1 m_2|} = \frac{\left| \frac{8}{3} - 2 \right|}{\left| 1 + \frac{8}{3} \times 2 \right|} = \frac{2}{19}$$

$$\text{where, } m_1 = \frac{3-1}{\frac{3}{4}-0} = \frac{2}{\frac{3}{4}} = \frac{8}{3}$$

$$m_2 = \frac{3-1}{1} = 2$$

8. In a circle with centre O, suppose A, P, B are three points on its circumference such that P is the mid-point of minor arc AB. Suppose when $\angle AOB = \theta$,

$$\frac{\text{area}(\Delta AOB)}{\text{area}(\Delta APB)} = \sqrt{5} + 2$$

If $\angle AOB$ is doubled to 2θ , then the ratio $\frac{\text{area}(\Delta AOB)}{\text{area}(\Delta APB)}$ is -

- (A) $\frac{1}{\sqrt{5}}$ (B) $\sqrt{5} - 2$ (C) $2\sqrt{3} + 3$ (D) $\frac{\sqrt{5} - 1}{2}$

Ans. [A]
Sol.

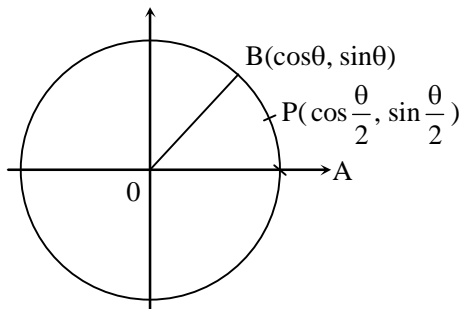

$$\frac{\Delta(AOB)}{\Delta APB} = 2 + \sqrt{5}$$

$$\frac{\frac{1}{2} \cdot 1 \cdot \sin \theta}{\frac{1}{2} \cdot 1 \cdot \sin \theta} = 2 + \sqrt{5} \text{ on solving}$$

$$\frac{\cos \frac{\theta}{2}}{1 - \cos \frac{\theta}{2}} = 2 + \sqrt{5} \Rightarrow \cos \frac{\theta}{2} = \frac{1 + \sqrt{5}}{4}$$

So $\cos \theta = \frac{\sqrt{5} - 1}{4}$

If $\theta \rightarrow 2\theta$

$$\frac{\Delta AOB}{\Delta APB} = \frac{\cos \theta}{1 - \cos \theta} = \frac{1}{\sqrt{5}}$$

9. $X = \{x \in \mathbb{R} : \cos(\sin x) = \sin(\cos x)\}$. The number of elements in X is -
(A) 0 (B) 2 (C) 4 (D) not finite

Ans. [A]
Sol.

$$\cos(\sin x) = \sin(\cos x)$$

$$\sin\left(\frac{\pi}{2} \pm \sin x\right) = \sin(\cos x)$$

$$\cos x = n\pi + (-1)^n \left(\frac{\pi}{2} + \sin x\right), n \in \mathbb{I}$$

$$\Rightarrow \cos x \pm \sin x = n\pi + (-1)^n \frac{\pi}{2}, n \in \mathbb{I}$$

As LHS $\in [-\sqrt{2}, \sqrt{2}]$, and it does not satisfies RHS

So No solution possible

10. A sphere with centre O sits atop a pole as shown in the figure. An observer on the ground is at a distance 50m from the foot of the pole. She notes that the angles of elevation from the observer to points P and Q on the sphere are 30° and 60° , respectively. Then, the radius of the sphere in meters is -

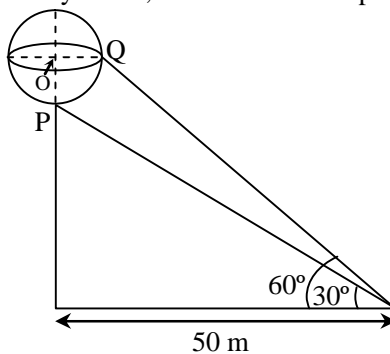

(A) $100\left(1 - \frac{1}{\sqrt{3}}\right)$

(B) $\frac{50\sqrt{6}}{3}$

(C) $50\left(1 - \frac{1}{\sqrt{3}}\right)$

(D) $\frac{100\sqrt{6}}{3}$

Ans. [C]

Sol.

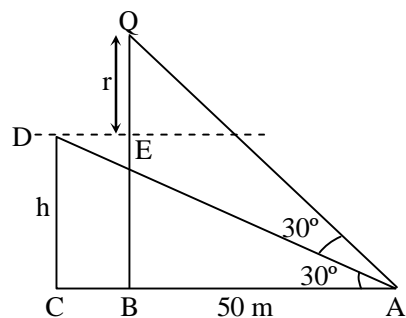

$$DE = BC = r$$

$$\tan 30^\circ = \frac{h}{50}$$

$$\boxed{h = \frac{50}{\sqrt{3}}}$$

$$\tan 60^\circ = \frac{h+r}{50-r}$$

$$\sqrt{3}(50-r) = h+r$$

$$\sqrt{3}(50-r) = \frac{50}{\sqrt{3}} + r$$

$$3(50-r) = 50 + \sqrt{3}r$$

$$100 = (3 + \sqrt{3})r$$

$$r = \frac{100}{3 + \sqrt{3}}$$

$$r = \frac{100(3 - \sqrt{3})}{6} = 50 \left(1 - \frac{1}{\sqrt{3}} \right)$$

11. The graph of the function $f(x) = x + \frac{1}{8} \sin(2\pi x)$, $0 \leq x \leq 1$ is shown below. Define $f_1(x) = f(x)$, $f_{n+1}(x) = f(f_n(x))$, for $n \geq 1$

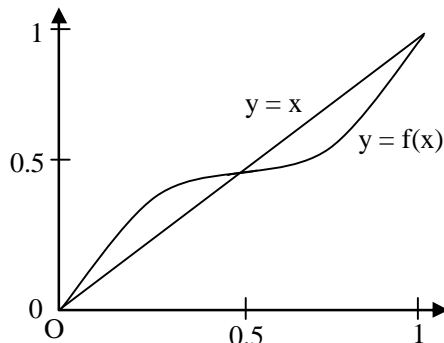

Which of the following statements are true ?

- I. There are infinitely many $x \in [0, 1]$ for which $\lim_{n \rightarrow \infty} f_n(x) = 0$
- II. There are infinitely many $x \in [0, 1]$ for which $\lim_{n \rightarrow \infty} f_n(x) = \frac{1}{2}$
- III. There are infinitely many $x \in [0, 1]$ for which $\lim_{n \rightarrow \infty} f_n(x) = 1$
- IV. There are infinitely many $x \in [0, 1]$ for which $\lim_{n \rightarrow \infty} f_n(x)$ does not exist

- (A) I and III only (B) II only (C) I, II, III only (D) I, II, III and IV

Ans. [B]

Sol. $\lim_{n \rightarrow \infty} f_n(x) = f(f(f(\dots \infty \text{ times } (x)))$

Now for $x_1 \in \left(0, \frac{1}{2}\right)$

$f(x_1) > x_1$ as $f(x)$ is concave - downward

Thus $f_n \rightarrow \frac{1}{2}$ as $n \rightarrow \infty$

Similarly for $x_1 \in \left(\frac{1}{2}, 1\right)$

$f(x_1) < x_1$ as $f(x)$ is concave upward

Thus $f_n \rightarrow \frac{1}{2}$ as $n \rightarrow \infty$

12. Limit $\lim_{x \rightarrow \infty} x^2 \int_0^x e^{t^3 - x^3} dt$ equals

- (A) $\frac{1}{3}$ (B) 2 (C) ∞ (D) $\frac{2}{3}$

Ans. [A]

Sol.
$$\lim_{x \rightarrow \infty} \frac{x^2 \int_0^x e^{t^3} dt}{e^{x^3}}$$

Apply L Hospital

$$\lim_{x \rightarrow \infty} \frac{2x \int_0^x e^{t^3} + x^2 e^{x^3}}{3x^2 e^{x^3}}$$

$$\lim_{x \rightarrow \infty} \frac{2 \int_0^x e^{t^3} + x e^{x^3}}{3x e^{x^3}}$$

$$\lim_{x \rightarrow \infty} \frac{2e^{x^3} + e^{x^3} + 3x^3 e^{x^3}}{3e^{x^3} + 9x^3 e^{x^3}}$$

$$\lim_{x \rightarrow \infty} \frac{3 + 3x^3}{3 + 9x^3} = \frac{1}{3}$$

13. The polynomial equation $x^3 - 3ax^2 + (27a^2 + 9)x + 2016 = 0$ has -
 (A) exactly one real root for any real a
 (B) three real roots for any real a
 (C) three real roots for any $a \geq 0$, and exactly one real root for any $a < 0$
 (D) three real roots for any $a \leq 0$, and exactly one real root for any $a > 0$

Ans. [A]

Sol.
$$f'(x) = 3x^2 - 6ax + 27a^2 + 9$$

$$= 3[x^2 - 2ax + 9a^2 + 3] = 3((x - a)^2 + 8a^2 + 3)$$

 $\therefore f'(x)$ is + ve for $x \in \mathbb{R}$ so $f(x)$ is monotonic \uparrow
 for $x \in \mathbb{R}$.

14. The area of the region bounded by the curve $y = |x^3 - 4x^2 + 3x|$ and the x-axis, $0 \leq x \leq 3$, is -
 (A) $\frac{37}{6}$ (B) $\frac{9}{4}$ (C) $\frac{37}{12}$ (D) 0

Ans. [C]

Sol.
$$A = \int_0^1 f(x) dx - \int_1^3 f(x) dx = \int_0^1 (x^3 - 4x^2 + 3x) dx - \int_1^3 (x^3 - 4x^2 + 3x) dx = \frac{37}{12}$$

15. The number of continuous function $f : [0, 1] \rightarrow [0, 1]$ such that $f(x) < x^2$ for all x and $\int_0^1 f(x) dx = \frac{1}{3}$ is :
 (A) 0 (B) 1 (C) 2 (D) infinite

Ans. [A]

Sol. $\therefore f(x)$ is always positive for $x \in [0, 1]$

$$\therefore f(x) < x^2 \Rightarrow \int_0^1 f(x) dx < \int_0^1 x^2$$

$$I < \frac{1}{3}$$

But it is given that $I = \frac{1}{3}$ which is not possible

16. On the real line \mathbb{R} , we define two functions f and g as follows :

$$f(x) = \min\{x - [x], 1 - x + [x]\}$$

$$g(x) = \max\{x - [x], 1 - x + [x]\}$$

Where $[x]$ denotes the largest integer not exceeding x . The positive integer n for which

$$\int_0^1 (g(x) - f(x)) dx = 100 \text{ is}$$

- (A) 100 (B) 198 (C) 200 (D) 202

Ans. [C]

Sol.

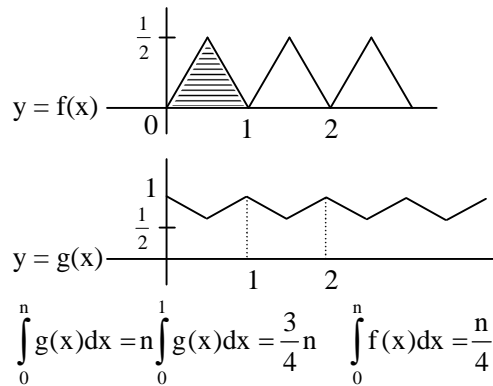

$$\int_0^n g(x) dx = n \int_0^1 g(x) dx = \frac{3}{4}n \quad \int_0^n f(x) dx = \frac{n}{4}$$

17. Let \vec{v} be a vector in the plane such that $|\vec{v} - \vec{i}| = |\vec{v} - 2\vec{i}| = |\vec{v} - \vec{j}|$. Then $|\vec{v}|$ lies in the interval -

- (A) (0, 1] (B) (1, 2] (C) (2, 3] (D) (3, 4]

Ans. [C]

Sol. V is the circumcentre of ΔABC

$$\forall A \equiv (1, 0), B \equiv (0, 1), C(2, 0)$$

Let $V(x, y)$

$$VA = VB = VC$$

$$(x - 1)^2 + y^2 = x^2 + (y - 1)^2 = (x - 2)^2 + y^2$$

$$(x, y) = \left(\frac{3}{2}, \frac{3}{2} \right)$$

$$\vec{V} = \frac{3\vec{i} + 3\vec{j}}{2}$$

$$|\vec{v}| = \frac{3}{\sqrt{2}} \in (2, 3)$$

18. A box contains b blue balls and r red balls. A ball is drawn randomly from the box and is returned to the box with another ball of the same colour. The probability that the second ball drawn from the box is blue is -

- (A) $\frac{b}{r+b}$ (B) $\frac{b^2}{(r+b)^2}$ (C) $\frac{b+1}{r+b+1}$ (D) $\frac{b(b+1)}{(r+b)(r+b+1)}$

Ans. [A]

Sol. $P(b_2) = P(b_1) \cdot P\left(\frac{b_2}{b_1}\right) + P(R_1) \cdot P\left(\frac{b_2}{R_1}\right) = \frac{b}{b+r} \cdot \frac{b+1}{b+r+1} + \frac{r}{b+r} \cdot \frac{b}{b+r+1} = \frac{b}{b+r}$

19. The number of noncongruent integer-sided triangles whose sides belong to the set $\{10, 11, 12, \dots, 22\}$ is -
 (A) 283 (B) 446 (C) 448 (D) 449

Ans. [C]

Sol. Number of scalene triangles

$$= {}^{13}C_3 - 3 \left\{ \begin{array}{l} 10,11,22 \\ 10,12,22 \\ 10,11,21 \end{array} \right\}$$

$$= 283$$

Number of isosceles triangles

$$= ({}^{13}C_2 \times 2) - 4 \left\{ \begin{array}{l} 10,10,22 \\ 11,11,22 \\ 10,10,21 \\ 10,10,20 \end{array} \right\}$$

$$= 152$$

Number of equilateral triangles

$$= {}^{13}C_1 = 13$$

So total number of triangles = 448

20. Suppose we have to cover the xy -plane with identical tiles such that no two tiles overlap and no gap is left between the tiles. Suppose that we can choose tiles of the following shapes; equilateral triangle, square, regular pentagon, regular hexagon. Then the tiling can be done with tiles of -
 (A) all four shapes (B) exactly three of the four shapes
 (C) exactly two of the four shapes (D) exactly one of the four shapes

Ans. [B]

Sol. We can cover the plane using squares definitely using equilateral triangle, we can also cover the plane. Also regular hexagon is made of equilateral triangles. But pentagon cannot cover the plane because of its shape.

PHYSICS

21. Physical processes are sometimes described visually by lines. Only the following can cross -
 (A) Streamlines in fluid flow (B) Lines of forces in electrostatics
 (C) Rays in geometrical optics (D) Lines of force in magnetism

Ans. [C]

Sol. A \Rightarrow If stream lines intersect then there will be two direction of fluid flow at a point, which is absurd.

B \Rightarrow Lines of forces in electrostatic never intersect

D \Rightarrow Line of force in magnetism never intersect each other.

22. Uniform ring of radius R is moving on a horizontal surface with speed v and then climbs up a ramp of inclination 30° to a height h . There is no slipping in the entire motion. Then h is
 (A) $v^2/2g$ (B) v^2/g (C) $3v^2/2g$ (D) $2v^2/g$

Ans. [B]

Sol. $\frac{1}{2} mV^2 + \frac{1}{2} mR^2 \left(\frac{V}{R} \right)^2 = mgh$ {Using conservation of energy}

$$m \left(\frac{V^2}{2} + \frac{V^2}{2} \right) = mgh$$

$$h = \frac{V^2}{g}$$

23. A gas at initial temperature T undergoes sudden expansion from volume V to $2V$. Then -
- (A) The process is adiabatic
 (B) The process is isothermal
 (C) The work done in this process is $nRT \ln_e(2)$ where n is the number of moles of the gas.
 (D) The entropy in the process does not change

Ans. [A]

Sol. In sudden expansion gas do not get enough time for exchange of heat.
 \therefore Process is adiabatic.

24. Photons of wavelength λ are incident on a metal. The most energetic electrons ejected from the metal are bent into a circular arc of radius R by a perpendicular magnetic field having a magnitude B . The work function of the metal is (Where symbols have their usual meanings) -

(A) $\frac{hc}{\lambda} - m_e + \frac{e^2 B^2 R^2}{2m_e}$ (B) $\frac{hc}{\lambda} + 2m_e \left(\frac{eBR}{2m_e} \right)^2$

(C) $\frac{hc}{\lambda} - m_e C^2 - \frac{e^2 B^2 R^2}{2m_e}$ (D) $\frac{hc}{\lambda} - 2m_e \left(\frac{eBR}{2m_e} \right)^2$

Ans. [D]

Sol. $R = \frac{mv}{qB}$

$$V = \frac{qBR}{m} = \frac{eBR}{m_e}$$

$$\frac{hc}{\lambda} - \phi = KE_{\max} \text{ (Einstein photo electric equation)}$$

$$\phi = \frac{hc}{\lambda} - KE_{\max}$$

$$= \frac{hc}{\lambda} - \frac{1}{2} m_e \left(\frac{eBR}{m_e} \right)^2$$

$$= \frac{hc}{\lambda} - 2m_e \left(\frac{eBR}{2m_e} \right)^2$$

25. A container is divided into two equal part I and II by a partition with a small hole of diameter d . The two partitions are filled with same ideal gas, but held at temperature $T_I = 150$ K and $T_{II} = 300$ K by connecting to heat reservoirs. Let λ_I and λ_{II} be the mean free paths of the gas particles in the two parts such that $d \gg \lambda_I$ and $d \gg \lambda_{II}$. Then λ_I/λ_{II} is close to -
- (A) 0.25 (B) 0.5 (C) 0.7 (D) 1.0

Ans. [C]

Sol. As dimension of hole is very small than mean path, then at equilibrium effusion rate of gas in both direction must be equal.

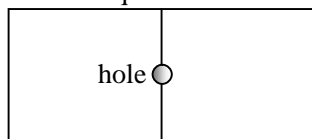

For this $\frac{P_1}{\sqrt{T_1}} = \frac{P_2}{\sqrt{T_2}}$

$$\text{Mean free path} \propto \frac{T}{P}$$

$$\frac{\lambda_1}{\lambda_2} = \frac{T_1}{T_2} \times \frac{P_2}{P_1}$$

$$\frac{T_1}{T_2} \times \frac{\sqrt{T_2}}{\sqrt{T_1}}$$

$$\frac{\lambda_1}{\lambda_2} = \sqrt{\frac{T_1}{T_2}} = \sqrt{\frac{150}{300}} = 0.7$$

26. A conducting bar of mass m and length ℓ moves on two frictionless parallel rails in the presence of a constant uniform magnetic field of magnitude B directed into the page as shown in the figure. The bar is given an initial velocity v_0 towards the right at $t = 0$. Then the

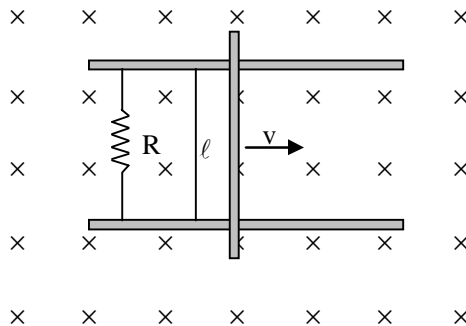

- (A) Induced current in the circuit is in the clockwise direction
 (B) Velocity of the bar decreases linearly with time
 (C) Distance the bar travels before it comes to a complete stop is proportional to R
 (D) Power generated across the resistance is proportional to ℓ

Ans. [C]

Sol. $F = iB\ell$

$$a = \frac{iB\ell}{m}$$

$$\phi = B.A$$

$$\frac{d\phi}{dt} = B \cdot \ell \cdot \left(\frac{dx}{dt} \right)$$

$$\varepsilon = (B \cdot \ell v)$$

$$i = \varepsilon/R = \frac{B \cdot \ell v}{R}$$

$$a = \left(\frac{B \ell v}{R} \right) \frac{B \ell}{m}$$

$$a = \frac{B^2 \ell^2}{Rm} \cdot v$$

$$\Rightarrow a = v \cdot \frac{dv}{dx}$$

$$\Rightarrow v \cdot \frac{dv}{dx} = \frac{B^2 \ell^2}{Rm} \cdot v$$

$$\Rightarrow \int dv = \frac{B^2 \ell^2}{Rm} \cdot \int dx$$

$$v = \frac{B^2 \ell^2}{Rm} \cdot 'X' \left[X = \frac{vRM}{B^2 \ell^2} \right]$$

27. A particle with total mechanical energy, which is small and negative, is under the influence of a one dimensional potential $U(x) = x^4/4 - x^2/2$ J Where x is in meters. At time $t = 0$ s, it is at $x = -0.5$ m. Then at a later time it can be found
- (A) Anywhere on the x axis
 (B) Between $x = -1.0$ m to $x = 1.0$ m
 (C) Between $x = -1.0$ m to $x = 0.0$ m
 (D) Between $x = 0.0$ m to $x = 1.0$ m

Ans. [C]

Sol. at $t = 0$, $x = 0.5$

$$u = \frac{x^4}{4} - \frac{x^2}{2} \Rightarrow \frac{1}{4} \times \frac{1}{16} - \frac{1}{4} \times \frac{1}{2} \Rightarrow \left| \frac{1}{4} \right|$$

$$\frac{du}{dx} = \frac{4x^3}{4} - \frac{2x}{2} = x^3 - x$$

$$\frac{du}{dx} = x(x^2 - 1)$$

$$\frac{du}{dx} = 0 \text{ at point of maxima \& minima}$$

$$x = 0; x = \pm 1$$

$$\left(\frac{d^2u}{dx^2} \right)_{x=0} = -1 \text{ point of maxima}$$

$$\left(\frac{d^2u}{dx^2} \right)_{x=\pm 1} = 2 \text{ point of minima}$$

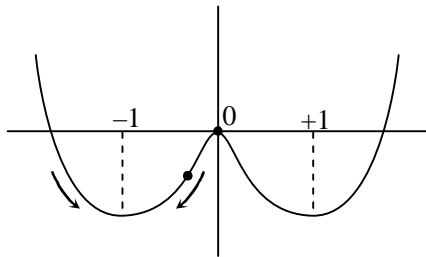

particle will found between $(-1, 0)$

28. A nurse measures the blood pressure of a seated patient to be 190 mm of Hg -
- (A) The blood pressure at the patient's feet is less than 190 mm of Hg
 (B) The actual pressure is about 0.25 times the atmospheric pressure
 (C) The blood pressure at the patient's neck is more than 190 mm of Hg
 (D) The actual pressure is about 1.25 times the atmospheric pressure

Ans. [D]

Sol. Blood pressure is gauge pressure = 190 mm Hg

Atmospheric pressure = 760 mm Hg

Actual pressure = 190 + 760 mm Hg = 950 mm Hg = 1.25 × 760 mm Hg

29. A particle at a distance of 1 m from the origin starts moving such that $dr/d\theta = r$, where (r, θ) are polar coordinates. Then the angle between resultant velocity and tangential velocity component is
 (A) 30 degrees (B) 45 degrees
 (C) 60 degrees (D) Dependent on where the particle is

Ans. [B]
 Sol.

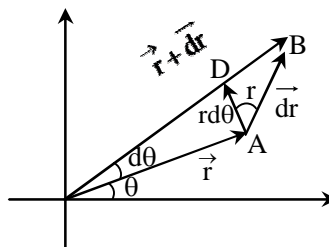
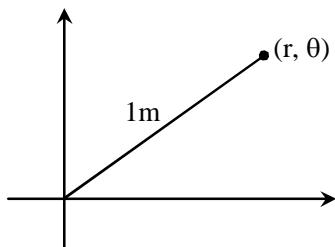

\vec{AB} = Direction of resultant velocity
 \vec{AD} = Direction of tangential velocity

$$\forall \tan \alpha = \frac{dr}{rd\theta} = \frac{r}{r}$$

$$\tan \alpha = 1$$

$$\alpha = 45^\circ$$

30. Electrons accelerated from rest by an electrostatic potential are collimated and sent through a Young's double slit setup. The fringe width is w . If the accelerating potential is doubled then the width is now close to -
 (A) 0.5 w (B) 0.7 w (C) 1.0 w (D) 2.0 w

Ans. [B]

Sol.

$$\beta = \frac{\lambda D}{d}$$

$$\lambda = \frac{h}{mV} = \frac{h}{\sqrt{2mq\Delta V}}$$

$$\beta \propto \lambda \quad \therefore \beta \propto \frac{1}{\sqrt{\Delta V}}$$

as ΔV is double

$$\therefore \beta \text{ is } \frac{1}{\sqrt{2}} \text{ times of } \beta_{\text{old}}$$

$$\therefore \beta_{\text{new}} = 0.7\beta$$

$$= 0.7w$$

31. A metallic sphere is kept in between two oppositely charged plates. The most appropriate representation of the field lines is -

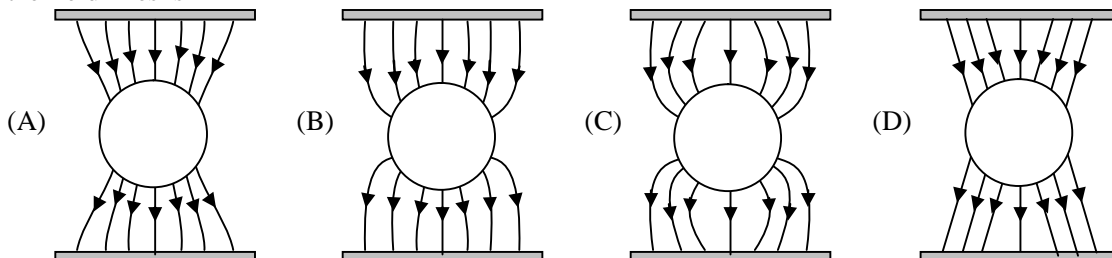

Ans. [B]

Sol. Electric field lines should be perpendicular to surface of metal.

32. An electron with kinetic energy E collides with a hydrogen atom in the ground state. The collision will be elastic
 (A) For all values of E (B) For $E < 10.2$ eV
 (C) For 10.2 eV $< E < 13.6$ eV only (D) For $0 < E < 3.4$ eV only

Ans. [B]

Sol. When e^- collide with atom which is massive in comparison to e^- . Max possible loss of KE = KE of e^- (initial KE) = E if this E is less than min excitation energy then collision is elastic
 $\therefore E < 10.2$ eV (Minimum excitation energy)

33. The continuous part of X-ray spectrum is a result of the
 (A) Photoelectric effect (B) Raman effect
 (C) Compton effect (D) Inverse photoelectric effect

Ans. [D]

Sol. Continuous X Ray is inverse of photoelectric effect

34. Thermal expansion of a solid is due to the
 (A) symmetric characteristic of the inter atomic potential energy curve of the solid
 (B) asymmetric characteristic of the inter atomic potential energy curve of the solid
 (C) double well nature of the inter-atomic potential energy curve of the solid
 (D) Rotational motion of the atoms of the solid

Ans. [B]

Sol. Thermal expansion of a solid is due to asymmetric characteristic of inter atomic potential energy curve of the solid.

35. An electron and a photon have same wavelength of 10^{-9} m. If E is the energy of the photon and p is the momentum of the electron, the magnitude of E/p in SI units is
 (A) 1.00×10^{-9} (B) 1.50×10^8 (C) 3.00×10^8 (D) 1.20×10^7

Ans. [C]

Sol. Energy of photon = $E = \frac{hc}{\lambda}$

Momentum of photon = $P = \frac{h}{\lambda}$

$E = PC \quad \therefore \frac{E}{P} = C = 3 \times 10^8$ m/s

36. If one takes into account finite mass of the proton, the correction to the binding energy of the hydrogen atom is approximately (mass of proton = 1.60×10^{-27} kg, mass of electron = 9.10×10^{-31} kg)-
 (A) 0.06 % (B) 0.0006 % (C) 0.02 % (D) 0.00 %

Ans. [A]

37. A monochromatic light source S of wavelength 440 nm is placed slightly above a plane mirror M as shown. Image of S in M can be used as a virtual source to produce interference fringes on the screen. The distance of source S from O is 20.0 cm, and the distance of screen from O is 100.0 cm (figure is not to scale). If the angle $\theta = 0.50 \times 10^{-3}$ radians, the width of the interference fringes observed on the screen is –

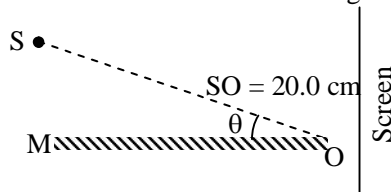

- (A) 2.20 mm (B) 2.64 mm (C) 1.10 mm (D) 0.55 mm

Ans. [B]

Sol.

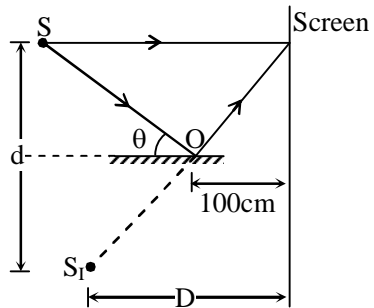
S and S_1 are source of YDSE $\theta = 0.5 \times 10^{-3}$ radian (very small)

$$D = SO \cos \theta + 100$$

$$= 20 \times 1 + 100$$

$$= 120 \text{ cm}$$

$$d = 2 \times SO \sin \theta$$

$$\Rightarrow 2 \times 20 \times \theta$$

$$\Rightarrow 40 \times 0.5 \times 10^{-3} \text{ cm}$$

$$2 \times 10^{-2} \text{ cm}$$

$$\beta = \frac{\lambda D}{d} = \frac{440 \times 10^{-6} \times 120 \times 10^2}{2 \times 10^{-2} \times 10^2}$$

$$264 \times 10^{-2}$$

$$\Rightarrow 2.64 \text{ mm}$$

38. A nuclear fuel rod generates energy at a rate of $5 \times 10^8 \text{ Watt/m}^3$. It is in the shape of a cylinder of radius 4.0 mm and length 0.20 m. A coolant of specific heat $4 \times 10^3 \text{ J/(kg-K)}$ flows past it at a rate of 0.2 kg/s. The temperature rise in this coolant is approximately -

(A) 2°C (B) 6°C (C) 12°C (D) 30°C

Ans. [B]

Sol.



$$\frac{dm}{dt} \times S \Delta T = \frac{d\theta}{dt}$$

$$\frac{d\theta}{dt} = 5 \times 10^8 \times \text{volume of rod}$$

$$= 5 \times 10^8 \times \pi \times (4)^2 \times 10^{-6} \times \frac{0.2}{10}$$

$$= 5 \times 10 \times \pi \times 16 \times 2$$

$$= 1600 \pi$$

$$0.2 \times 4 \times 10^3 \Delta T = 1600 \pi$$

$$8 \times 10^2 \Delta T = 16 \times 10^2 \pi$$

$$\Delta T = 3.14 \times 2$$

$$\Rightarrow 6.28^\circ\text{C}$$

$$\frac{dB_p}{dx} = 0 \text{ for minima of } B_p$$

$$\Rightarrow \frac{\mu_0 I_1}{2\pi} \left[\frac{-1}{x^2} \right] + \frac{\mu_0 I_2}{2\pi} \frac{1}{(4-x)^2} = 0$$

$$\frac{I_1}{x^2} = \frac{I_2}{(4-x)^2}$$

$$\frac{I_1}{I_2} = \left(\frac{x}{4-x} \right)^2$$

$$\frac{I_1}{I_2} = \left(\frac{1}{4-1} \right)^2$$

$$\frac{I_2}{I_1} = \frac{9}{1}$$

CHEMISTRY

41. The shape of SCl_4 is best described as a
 (A) square (B) tetrahedron (C) square pyramid (D) see-saw

Ans. [D]

Sol. $\text{SCl}_4 \Rightarrow 4\text{b.p} + 1 \ell.\text{p.}$

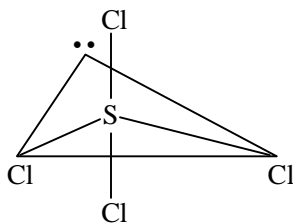

42. Among the following atomic orbital overlap, the non-bonding overlap is

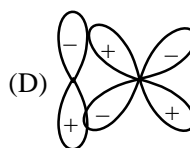
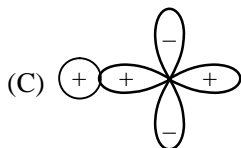
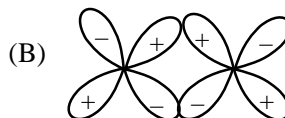
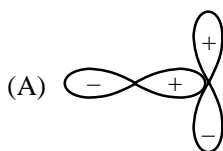

Ans. [A]

Sol. It has +ve & -ve overlap both simultaneous. So it leads to non-bonding overlap.

43. Among the following complexes, the one that can exhibit optical activity is
 (A) $[\text{CoCl}_6]^{3-}$ (B) $[\text{Co}(\text{en})\text{Cl}_4]^-$ (C) $\text{cis}-[\text{Co}(\text{en})_2\text{Cl}_2]^{3+}$ (D) $\text{trans}-[\text{Co}(\text{en})_2\text{Cl}_2]^+$

Ans. [C]

Sol.

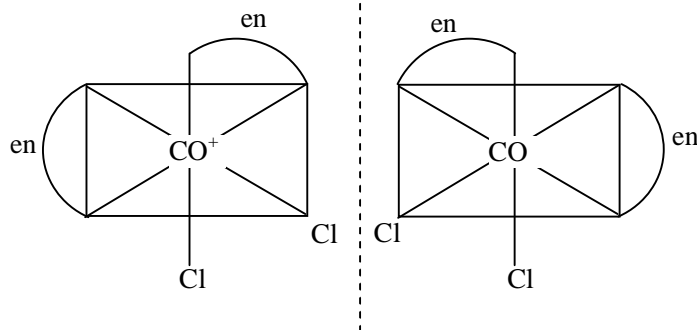

44. The pK_a of oxoacids of chlorine in water follows the order
 (A) $\text{HClO} < \text{HClO}_3 < \text{HClO}_2 < \text{HClO}_4$ (B) $\text{HClO}_4 < \text{HClO}_3 < \text{HClO}_2 < \text{HClO}$
 (C) $\text{HClO}_4 < \text{HClO}_2 < \text{HClO}_3 < \text{HClO}$ (D) $\text{HClO}_2 < \text{HClO} < \text{HClO}_3 < \text{HClO}_4$

Ans. [B]

Sol. Acidic strength of acid is
 $\text{HClO}_4 > \text{HClO}_3 > \text{HClO}_2 > \text{HClO}$
 $[\text{H}^+] \uparrow \quad k_a \uparrow \quad p^{k_a} \downarrow$

$\therefore p^{k_a}$ order $\text{HClO}_4 < \text{HClO}_3 < \text{HClO}_2 < \text{HClO}$

45. The packing efficiency of the face centered cubic (fcc), body centered cubic (bcc) and simple / primitive cubic (pc) lattices follows the order
 (A) $\text{fcc} > \text{bcc} > \text{pc}$ (B) $\text{bcc} > \text{fcc} > \text{pc}$ (C) $\text{pc} > \text{bcc} > \text{fcc}$ (D) $\text{bcc} > \text{pc} > \text{fcc}$

Ans. [A]

Sol.

	FCC	BCC	SC
η	74%	68%	52.4%

order $\text{FCC} > \text{BCC} > \text{SC}$

46. The ratio of root mean square velocity of hydrogen at 50 K to that of nitrogen at 500 K is closest to
 (A) 1.18 (B) 0.85 (C) 0.59 (D) 1.40

Ans. [A]

Sol. $V_{\text{rms}} = \sqrt{\frac{3RT}{M}}$

$$\frac{(V_{\text{rms}})_{\text{H}_2}}{(V_{\text{rms}})_{\text{O}_2}} = \frac{\sqrt{\frac{3 \times R \times 50}{2}}}{\sqrt{\frac{3 \times R \times 500}{28}}} = 1.18$$

47. The molecule with the highest dipole moment among the following is
 (A) NH_3 (B) NF_3 (C) CO (D) HF

Ans. [D]

Sol. $\mu \propto \Delta E \cdot N$

So HF has highest value of dipole moment

48. The most stable Lewis acid-base adduct among the following is
 (A) $\text{H}_2\text{O} \rightarrow \text{BCl}_3$ (B) $\text{H}_2\text{S} \rightarrow \text{BCl}_3$ (C) $\text{H}_3\text{N} \rightarrow \text{BCl}_3$ (D) $\text{H}_3\text{P} \rightarrow \text{BCl}_3$

Ans. [C]

Sol. Greater is the tendency to donate $\ell.p$ more stable will be the Lewis acid-base adduct.

49. The reaction of D-glucose with ammoniacal AgNO_3 produces

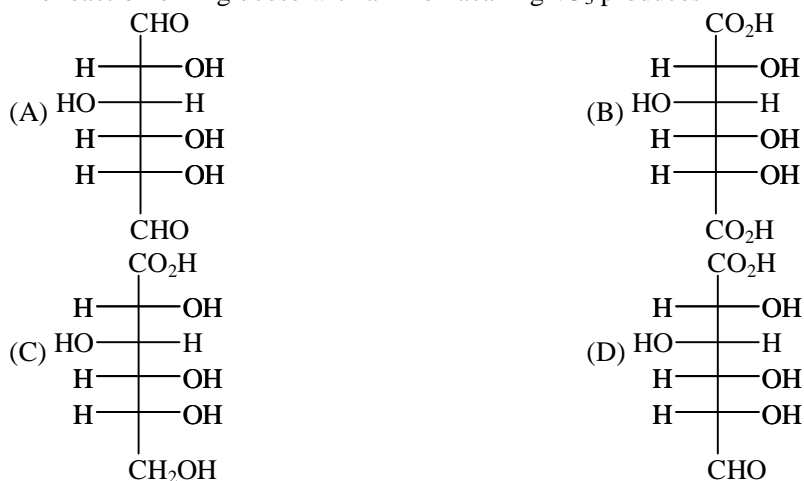

Ans. [C]
Sol.

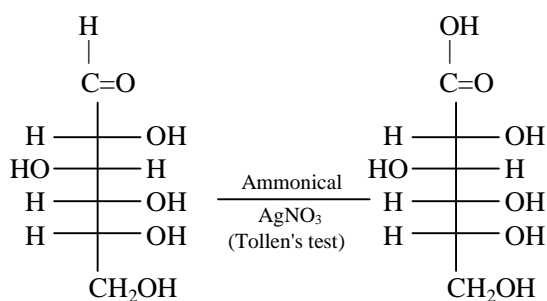

D-Glucose

* Tollen's reagent oxidise aldehyde group $\left(\begin{array}{c} -\text{C}-\text{H} \\ || \\ \text{O} \end{array} \right)$ in to carboxylic acid $\left(\begin{array}{c} -\text{C}-\text{OH} \\ || \\ \text{O} \end{array} \right)$.

50. The reagent (s) used for the conversion of benzene diazonium hydrogensulfate to benzene is / are -

- (A) H_2O (B) $\text{H}_3\text{PO}_2 + \text{H}_2\text{O}$ (C) $\text{H}_2\text{SO}_4 + \text{H}_2\text{O}$ (D) CuCl / HCl

Ans. [B]
Sol.

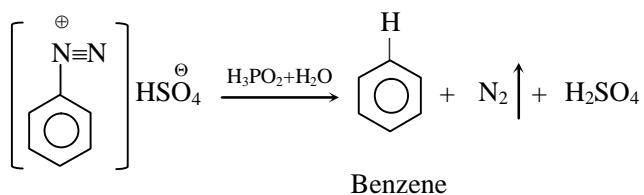

51. The major product obtained in the reaction of toluene with 1-bromo-2-methyl propane in the presence of anhydrous AlCl_3 is

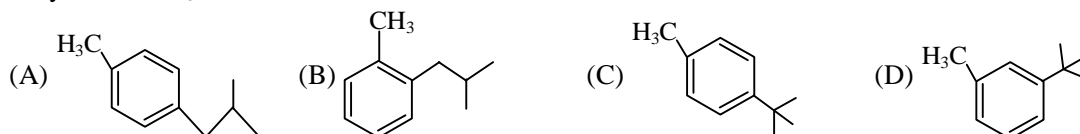

Ans. [C]

Sol.

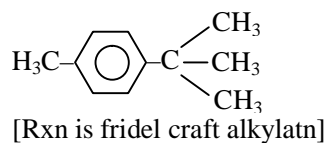
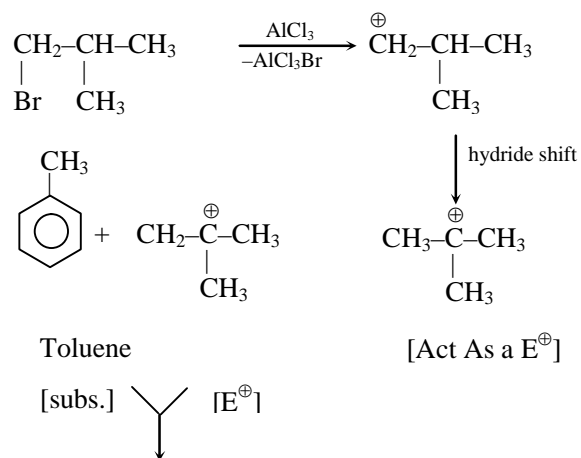

52. The major product in the following reaction is

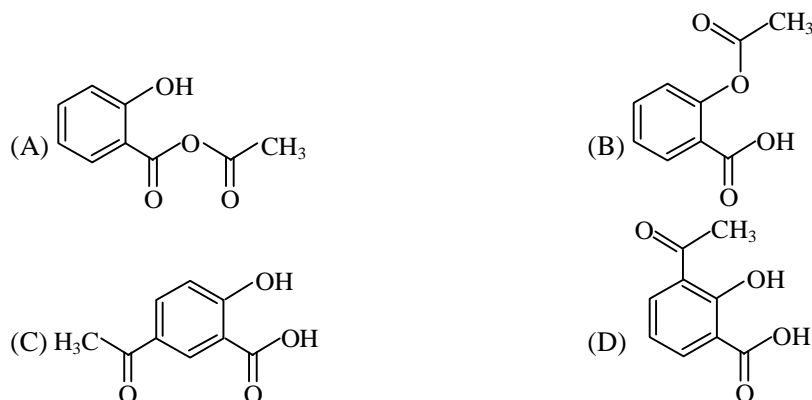
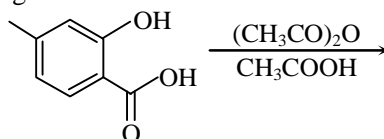
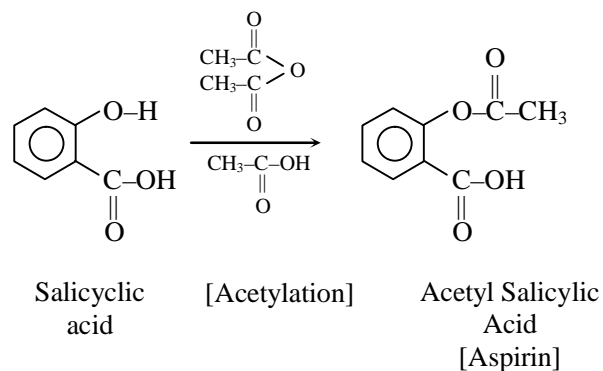
Ans. [B]
Sol.

53. The compounds containing sp hybridized carbon atom are

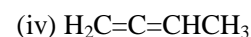
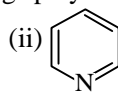
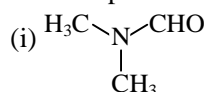

(A) (i) and (ii)

(B) (iii) and (iv)

(C) (ii) and (iii)

(D) (i) and (iv)

Ans. [B]

Sol.

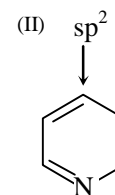
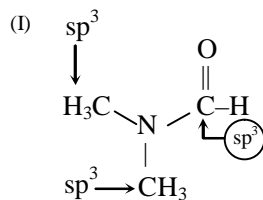

(III)

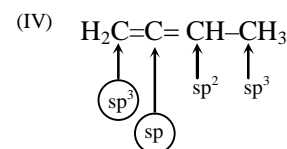
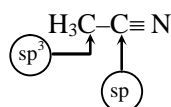

III & IV compound contain sp hybridised carbon

54. Upon heating with acidic KMnO_4 an organic compound produces hexan-1,6-dioic acid as the major product the starting compound is

(A) benzene

(B) cyclohexene

(C) 1-methylcyclohexene

(D) 2-methylcyclohexene

Ans. [B]

Sol.

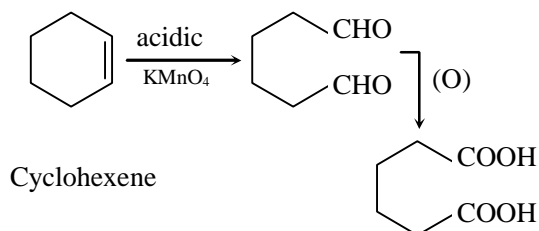

Cyclohexene

Hexane-1,6-dioic acid

55. It takes 1h for a first order reaction to go to 50% completion. The total time required for the same reaction to reach 87.5% completion will be

(A) 1.75 h

(B) 6.00 h

(C) 3.50 h

(D) 3.00 h

Ans. [D]

Sol.

$$t_{1/2} = 1 \text{ hr}$$

$$t_{87.5} = \frac{2.303}{k} \log \frac{a}{a-x}$$

$$= \frac{2.303}{0.693} \log \frac{a}{a-.875}$$

$$= \frac{2.303}{0.693} \log 8$$

$$= \frac{2.303}{0.693} \times 3 \times .3010$$

$$= 3$$

56. A unit cell of calcium fluoride has four calcium ions. The number of fluoride ions in the unit cell is
 (A) 2 (B) 4 (C) 6 (D) 8

Ans. [D]

Sol. No. of F^- will be equal to eight since for one Ca^{+2} there should be two F^- ion.

57. The equilibrium constant of a 2 electron redox reaction at 298 K is 3.8×10^{-3} . The cell potential E° (in V) and the free energy change ΔG° (in kJ mol^{-1}) for this equilibrium respectively, are
 (A) $-0.071, -13.8$ (B) $-0.071, 13.8$
 (C) $0.71, -13.8$ (D) $0.071, -13.8$

Ans. [B]

Sol. $\Delta G^\circ = -2.303 \times 8.314 \times 298 \log (3.8 \times 10^{-3}) \text{ J}$
 $= 13809.3876 \text{ J} = 13.809 \text{ KJ}$

$$\Delta G^\circ = -nFE^\circ$$

$$13809.387 = -2 \times 96500 \times E^\circ$$

$$E^\circ_{\text{cell}} = .071$$

58. The number of stereoisomer possible for the following compound is



- (A) 2 (B) 3 (C) 4 (D) 8

Ans. [C]

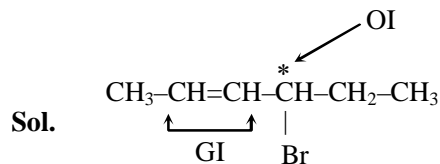

$n=2$ [No. of stereogenic area]

Total stereoisomer = 2^n

[When symm. is/are absent]

Total stereo isomer = $2^2 = 4$

59. In the radioactive disintegration series ${}_{90}^{232}\text{Th} \longrightarrow {}_{82}^{208}\text{Pb}$, involving α and β decay, the total number of α and β particles emitted are

- (A) 6 α and 6 β (B) 6 α and 4 β
 (C) 6 α and 5 β (D) 5 α and 6 β

Ans. [B]

Sol. no. of α -particle = $\frac{232 - 208}{4} = 6$

no. of β -particle = 4

60. In the following compressibility factor (Z) vs pressure graph at 300 K, the compressibility of CH_4 at pressure < 200 bar deviates from ideal behaviour because

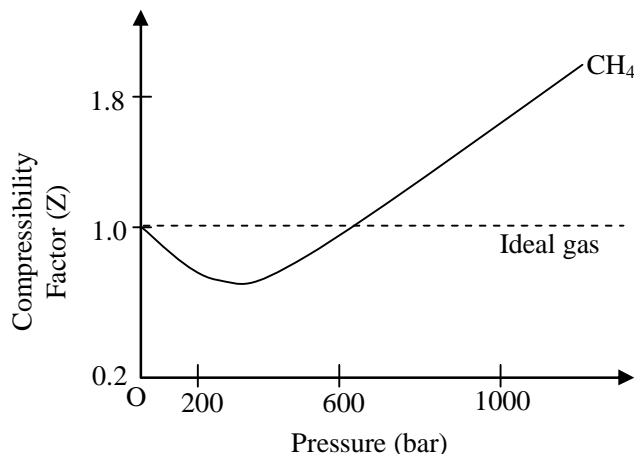

- (A) The molar volume of CH_4 is less than its molar volume in the ideal state
 (B) The molar volume of CH_4 is same as that in its ideal state
 (C) Intermolecular interactions between CH_4 molecules decreases
 (D) The molar volume of CH_4 is more than its molar volume in the ideal state

Ans. [A]

Sol. $Z = \frac{(V_M)_r}{(V_M)_i} < 1$ at $p < 200$ bar
 $\therefore (V_M)_r < (V_M)_i$

BIOLOGY

61. Which of the following molecules is a primary acceptor of CO_2 in photosynthesis ?
 (A) Pyruvate (B) 3-phosphoglycerate
 (C) Phosphoenol pyruvate (D) Oxaloacetate

Ans. [C]

Sol. In C_4 plants the primary acceptor of CO_2 is phosphoenol pyruvate, a 3C compound. e.g. In Maize, Sugarcane etc.

62. Which one of the following pairs of molecules never forms a hydrogen bond between them ?
 (A) Water and water (B) Water and glucose
 (C) Water and ethanol (D) Water and octane

Ans. [D]

Sol. Hydrogen bond is a weak bond between two molecules resulting from an electrostatic attraction between a proton in one molecule and an electronegative atom in another molecule. This is not possible in case of water and octane

63. Lactase hydrolyses lactose into
 (A) Glucose + glucose (B) Glucose + galactose
 (C) Galactose + galactose (D) Galactose + fructose

Ans. [B]

Sol. Lactose $\xrightarrow{\text{Lactase}}$ Glucose + Galactose

64. Which of the following statements is incorrect regarding biological membrane ?

- (A) It is composed of lipids and proteins
- (B) Peripheral proteins are loosely associate with the membrane
- (C) Integral proteins span the lipid bilayer
- (D) Lipids and membrane proteins do not provide structural and functional asymmetry

Ans. [D]

Sol. Proteins provide asymmetry to plasma membrane, as they are of 2 types i.e. peripheral and integral.

65. The percentage of sunlight captured by plants is

- (A) 2-10%
- (B) 10-20%
- (C) 60-80%
- (D) 100%

Ans. [A]

Sol. Plants capture 2-10 % of PAR

66. The hard outer layer of pollens, named exine, is made of

- (A) cellulose
- (B) tapetum
- (C) sporopollenin
- (D) pectin

Ans. [C]

Sol. Sporopollenin forms the exine of pollen grain which is resistant to acids, high temperature and radiations.

67. Insectivorous plants such as Venus fly trap catch and digest insects in order to supplement the deficiency of

- (A) Sulphur
- (B) Nitrogen
- (C) Potassium
- (D) Phosphorus

Ans. [B]

Sol. Insectivorous plants grow in Nitrogen deficient soils and in order to compensate the deficiency they catch and digest insects and obtain N from chitin (NAG).

68. Which of the following statements about nucleosome is true ?

- (A) It consists of only DNA
- (B) It is a nucleus-like structure found in prokaryotes
- (C) It consists of DNA and proteins
- (D) It consists of only histone proteins

Ans. [C]

Sol. Nucleosome is the smallest unit of DNA packaging containing 200 nitrogen bases and four types of histone proteins i.e. H₂A, H₂B, H₃ and H₄. H₁ type of histone is used in plugging.

69. Epithelial cells in animals are held by specialized junctions, one of them being "Gap junction". Function of a "Gap junction" is to

- (A) Facilitate cell-cell communication by rapid transfer of small molecules
- (B) Cement the neighbouring cells
- (C) Stop substances from leaking
- (D) Provide gaps in the tissue to facilitate uptake of small molecules across tissues

Ans. [A]

Sol. Gap junctions are cytoplasmic communications between two epithelial cells for rapid transfer of some ions and small molecule

70. Which of the following statements is true about glandular epithelium in salivary gland ?

- (A) It consists of isolated single cells
- (B) It consists of mutlicellular cluster of cells
- (C) Its secretions are endocrine
- (D) It consists of squamous epithelial cells

Ans. [B]

Sol. Salivary gland is multicellular exocrine gland, made up cuboidal epithelium.

71. Which one of the following ion pairs is involved in nerve impulses ?
 (A) Na^+ , K^+ (B) Na^+ , Cl^- (C) K^+ , Cl^- (D) K^+ , Ca^{2+}
Ans. [A]
Sol. Na^+ - K^+ pump is essential for impulse conduction
72. Which of the following hormones that controls blood pressure is secreted by human heart ?
 (A) Erythropoietin (B) Atrial natriuretic factor
 (C) ACTH (D) Glucocorticoid
Ans. [B]
Sol. ANF [Anti-Natriuretic Factor] is antagonist of Renin Hormone and act as Vasodilator to reduce blood pressure. ANF is secreted from heart.
73. Oxytocin and vasopressin are synthesized in
 (A) Hypothalamus (B) Adrenal gland
 (C) Pituitary gland (D) Ovary
Ans. [A]
Sol. Oxytocin and Vasopressin synthesised in hypothalamus then comes into neurohypophysis of pituitary gland to release in blood
 [Given answer by KVPY is C]
74. If you exhale multiple times into a conical flask containing lime water through a single inlet fixed through a stop cork, lime water will ?
 (A) Become cooler (B) Turn milky
 (C) Remain unchanged (D) Turn yellow
Ans. [B]
Sol. Exhaled air has CO_2 in it.

$$\text{Ca}(\text{OH})_2 + \text{CO}_2 \rightarrow \text{CaCO}_3 + \text{H}_2\text{O}$$
 Lime water Exhaled air Milky white ppt
 So lime water become milky white.
75. The path of passage of stimulus when you accidentally touch a hotplate is
 (A) Receptor \rightarrow Brain \rightarrow Muscles (B) Muscles \rightarrow Spinal cord \rightarrow Receptor
 (C) Muscles \rightarrow Brain \rightarrow Receptor (D) Receptor \rightarrow Spinal cord \rightarrow Muscles
Ans. [D]
Sol. Reflex arch
 Receptor \rightarrow Sensory Neuron \rightarrow Spinal cord \rightarrow Motor neuron \rightarrow Muscle [Effector]
76. In the presence of glucose and lactose, *Escherichia coli* utilizes glucose. However, lactose also enters the cells because
 (A) low level of permease is always present in the cell
 (B) it uses the same transporter as glucose
 (C) it diffuses through the bacterial cell membrane
 (D) it is transported through porins
Ans. [A]
Sol. The preferred molecule is glucose first, then lactose is used by *E.coli* because ultimately lactose is also broken down into galactose and glucose. Permease is a carrier protein which helps in facilitated diffusion. Lac operon is always operational at low levels.
77. Passive immunization is achieved by administering
 (A) Heat killed vaccines (B) Toxoids (C) Live attenuated vaccines (D) Antibodies
Ans. [D]
Sol. Administration of already prepared antibodies is called passive immunisation

78. Which of the following anions neutralize the acidic pH of the chyme that enters into the duodenum from the stomach ?
 (A) H_2PO_4^- (B) HSO_4^- (C) HCO_3^- (D) CH_3COO^-
- Ans.** [C]
Sol. Duodenum receives Bile and Pancreatic juice alkaline in nature due to high amount of HCO_3^- anion which helps in neutralization of acidity of chyme.
79. If $^{14}\text{CO}_2$ is added to a suspension of photosynthesizing chloroplasts, which of the following will be the first compound to be radioactive ?
 (A) ATP (B) NADPH (C) NADH (D) 3-phosphoglycerate
- Ans.** [D]
Sol. During Calvin cycle, the $^{14}\text{CO}_2$ is incorporated with a 5C compound Ribulose 1-5 Biphosphate and forms 2 molecules of 3C compound 3-phosphoglycerate.
80. Which of the following species makes the largest true flower in the world ?
 (A) *Amorphophallus titanum* (B) *Rafflesia arnoldii*
 (C) *Nelumbo nucifera* (D) *Helianthus annuus*
- Ans.** [B]
Sol. *Rafflesia arnoldii* is the total root parasite and forms the largest flower in angiosperms while *Amorphophallus titanum* is the largest inflorescence in the angiosperms

Part – II

Two - Mark Questions

MATHEMATICS

81. The remainder when the polynomial $1 + x^2 + x^4 + x^6 + \dots + x^{22}$ is divided by $1 + x + x^2 + x^3 + \dots + x^{11}$ is -
 (A) 0 (B) 2
 (C) $1 + x^2 + x^4 + \dots + x^{10}$ (D) $2(1 + x^2 + x^4 + \dots + x^{10})$
- Ans.** [D]
Sol. $P(x) = 1 + x^2 + x^4 + x^6 + \dots + x^{22} = (1 + x^2)(1 + x^4)(1 + x^4 + x^8)(1 - x^4 + x^8)$
 $Q(x) = 1 + x + x^2 + x^3 + \dots + x^{11} = (1 + x)(1 + x^2)(1 + x^4 + x^8)$

$$\frac{P(x)}{Q(x)} = \frac{(1 + x^2)(1 - x^4 + x^8)}{(1 + x)} = \frac{1 - x^4 + x^8 + x^4 - x^8 + x^{12}}{1 + x} = \frac{1 + x^{12}}{1 + x}$$
 Remainder. When $(1 + x^{12})$ is divided by $(1 + x)$ is = 2
 Now remainder $P(x)$ divided by $Q(x)$
 $= 2(1 + x^2)(1 + x^4 + x^8)$
 $= 2(1 + x^2 + \dots + x^{10})$
82. The range of the polynomial $p(x) = 4x^3 - 3x$ as x varies over the interval $\left(-\frac{1}{2}, \frac{1}{2}\right)$ is
 (A) $[-1, 1]$ (B) $(-1, 1)$ (C) $(-1, 1)$ (D) $\left(-\frac{1}{2}, \frac{1}{2}\right)$
- Ans.** [C]
Sol. $P'(x) = 12x^2 - 3 = 3(4x^2 - 1)$
 In $\left(-\frac{1}{2}, \frac{1}{2}\right)$ $P'(x) < 0$
 $\Rightarrow P(x)$ is decreasing
 $\Rightarrow \text{Range} \in (P(-1), P(1))$
 Range $\in (-1, 1)$

83. Ten ants are on the real line. At time $t = 0$, the k -th ant starts at the point k^2 and travelling at uniform speed, reaches the point $(11 - k)^2$ at time $t = 1$. The number of distinct times at which at least two ants are at the same location is
 (A) 45 (B) 11 (C) 17 (D) 9

Ans. [C]

Sol. Velocity of any ant $U = (11 - k)^2 - k^2 = 22 - 2k$
 Now at any time distance travelled by any ant will be
 $S = S_0 + ut$

Where S_0 is the initial position

Now two ants will be at same position

If $S_i = S_j$

$$k_i^2 - 22 k_i t + 121 t = k_j^2 - 22 k_j t + 121 t$$

$$t = \frac{k_j^2 - k_i^2}{22(k_j - k_i)} ; t = \frac{k_j + k_i}{22} \text{ (as } k_i \neq k_j \text{)}$$

Now for $i = 1$

Values of t will be $\frac{3}{22}, \frac{4}{22}, \frac{5}{22}, \dots, \frac{11}{22}$ (9 values)

$i = 2$

values of t will be $\frac{4}{22}, \frac{5}{22}, \dots, \frac{11}{22}, \frac{12}{22}$

We can see there is only 1 distinct value

Similarly of $i = 3, 4, 5, 6, 7, 8, 9$ we get only 1 distinct value each.

So in all there 17 distinct values of 't'

84. A wall is inclined to the floor at an angle of 135° . A ladder of length ℓ is resting on the wall. As the ladder slides down, its mid-point traces an arc of an ellipse. Then the area of the ellipse is

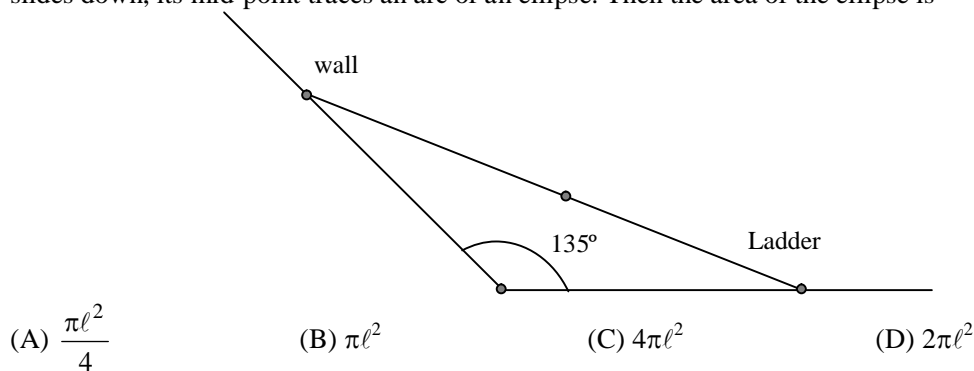

Ans. [A]

Sol.

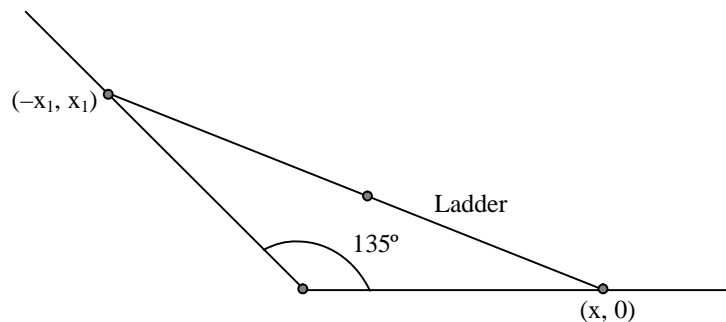

$$\text{Mid point (h, k)} = \left(\frac{x + x_1}{2}, \frac{y + y_1}{2} \right)$$

$$\text{Now } (x + x_1)^2 + (y + y_1)^2 = \ell^2$$

$$\text{As } 2h + 2k = x + x_1, 2k = x,$$

So required locus is

$$4(h + 2k)^2 + 4k^2 = \ell^2$$

$$h^2 + 5k^2 + 4hk = \frac{\ell^2}{4}$$

$$x^2 + 5y^2 + 4xy = \frac{\ell^2}{4}$$

$$\text{Whose area is } \frac{\pi \ell^2}{4}$$

85. Let AB be a sector of a circle with centre O and radius d, $\angle AOB = \theta \left(< \frac{\pi}{2} \right)$, and D be a point on OA such that BD is perpendicular to OA. Let E be the midpoint of BD and F be a point on the arc AB such that EF is parallel to OA. Then the ratio of length of the arc AF to the length of the arc AB is -

- (A) $\frac{1}{2}$ (B) $\frac{\theta}{2}$ (C) $\frac{1}{2} \sin \theta$ (D) $\frac{\sin^{-1} \left(\frac{1}{2} \sin \theta \right)}{\theta}$

Ans. [D]
Sol.

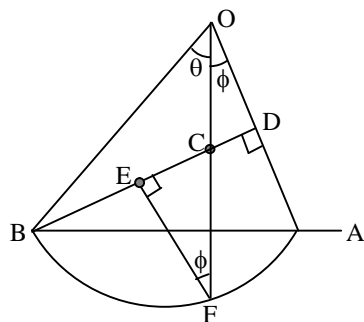

$$CF = r(1 - \cos \theta \sec \phi)$$

$$EC = r(\sin \phi - \cos \theta \tan \phi)$$

$$CD = r \cos \theta \tan \phi$$

$$EC + CD = ED$$

$$r \sin \phi = \frac{r \sin \theta}{2}$$

$$\phi = \sin^{-1} \left(\frac{\sin \theta}{2} \right)$$

86. Let $f(x)$ be a non-negative differentiable function on $[0, \infty)$ such that $f(0) = 0$ and $f'(x) \leq 2f(x)$ for all $x > 0$. Then, on $[0, \infty)$
- (A) $f(x)$ is always a constant function (B) $f(x)$ is strictly increasing
(C) $f(x)$ is strictly decreasing (D) $f(x)$ changes sign

Ans. [A]

Sol. $f'(x) \leq 2f(x)$

$$f'(x)e^{-2x} \leq 2f(x)e^{-2x}$$

$$\frac{d}{dx}(f(x)e^{-2x}) \leq 0$$

$g(x) = f(x)e^{-2x}$ is non-Increasing function

$$x \geq 0$$

$$g(x) \leq g(0)$$

$$f(x)e^{-2x} \leq f(0)e^{-0}$$

$$f(x)e^{-2x} \leq 0$$

$$f(x) \leq 0 \quad \text{but given } f(x) \text{ is not negative}$$

$$\therefore f(x) = 0 \quad \text{Constant function}$$

87. For each positive real number λ , let A_λ be the set of all natural numbers n such that $|\sin(\sqrt{n+1}) - \sin(\sqrt{n})| < \lambda$.

Let A_λ^c be the complement of A_λ in the set of all natural numbers. Then -

(A) $A_{\frac{1}{2}}, A_{\frac{1}{3}}, A_{\frac{1}{5}}$ are all finite sets

(B) $A_{\frac{1}{3}}$ is a finite set but $A_{\frac{1}{2}}, A_{\frac{1}{5}}$ are infinite sets

(C) $A_{\frac{1}{2}}^c, A_{\frac{1}{3}}^c, A_{\frac{1}{5}}^c$ are all finite sets

(D) $A_{\frac{1}{3}}, A_{\frac{1}{5}}$ are finite sets and $A_{\frac{1}{2}}$ is an infinite set

Ans. [C]

Sol. As $n \rightarrow \infty$

$$|\sin \sqrt{x+1} - \sin \sqrt{x}| \rightarrow 0$$

\therefore There exist infinite natural numbers for which

$$|\sin \sqrt{x+1} - \sin \sqrt{x}| < \lambda \quad \forall \lambda > 0$$

Hence $A_{\frac{1}{2}}, A_{\frac{1}{3}}, A_{\frac{1}{5}}$ are all infinite sets

88. Let f be a continuous function defined on $[0, 1]$ such that $\int_0^1 f^2(x) dx = \left(\int_0^1 f(x) dx \right)^2$. Then the range of f

(A) has exactly two points

(B) has more than two points

(C) is the interval $[0, 1]$

(D) is a singleton

Ans. [D]

Sol. By Cauchy Schwarz inequality

$$\left\{ \int_a^b f(x)g(x) dx \right\}^2 \leq \int_a^b (f(x))^2 dx \int_a^b (g(x))^2 dx$$

Here $g(x) = 1$

and equality holds only when $\frac{f(x)}{g(x)} = \lambda$

So, $f(x)$ is constant

89. Three schools send 2, 4 and 6 students, respectively, to a summer camp. The 12 students must be accommodated in 6 rooms numbered 1,2,3,4,5,6 in such a way that each room has exactly 2 students and both from the same school. The number of ways, the students can be accommodated in the rooms is -

(A) 60

(B) 45

(C) 32400

(D) 2700

Ans. [C]

Sol. $\frac{\sqrt[4]{4}}{(2)^2 \sqrt{2}} \times \frac{\sqrt[6]{6}}{(2)^3 \sqrt{3}} \times \sqrt[6]{6}$
 $= 32400$

90. Let a be a fixed non-zero complex number with $|a| < 1$ and $w = \left(\frac{z-a}{1-\bar{a}z} \right)$. Where z is a complex number.

Then

(A) there exists a complex number z with $|z| < 1$ such that $|w| > 1$

(B) $|w| > 1$ for all z such that $|z| < 1$

(C) $|w| < 1$ for all z such that $|z| < 1$

(D) there exists z such with $|z| < 1$ and $|w| = 1$

Ans. [C]

Sol. $|a| < 1$ & $w = \left(\frac{z-a}{1-\bar{a}z} \right) \Rightarrow w - \bar{a}zw = z - a$

$$\Rightarrow w + a = z(1 + \bar{a}w)$$

$$z = \frac{w+a}{1+\bar{a}w}$$

Given $|z| < 1$

$$\left| \frac{w+a}{1+\bar{a}w} \right| < 1 \Rightarrow |w+a|^2 < |1+\bar{a}w|^2$$

$$\Rightarrow (w+a)(\bar{w}+\bar{a}) < (1+\bar{a}w)(1+\bar{a}\bar{w})$$

$$\Rightarrow w\bar{w} + w\bar{a} + a\bar{w} + a\bar{a} < 1 + \bar{a}w + a\bar{w} + a\bar{a}w\bar{w}$$

$$\Rightarrow a\bar{a} \cdot w\bar{w} - w\bar{w} - a\bar{a} + 1 > 0$$

$$\Rightarrow |a|^2 |w|^2 - |w|^2 - |a|^2 + 1 > 0$$

$$\Rightarrow (|a|^2 - 1)(|w|^2 - 1) > 0$$

$$\text{Given } |a| < 1 \quad |w|^2 - 1 < 0$$

$$|w| < 1 \text{ \& } |z| < 1$$

PHYSICS

91. A light balloon filled with helium of density ρ_{He} is tied to a long light string of length ℓ and the string is attached to the ground. If the balloon is displaced slightly in the horizontal direction from the equilibrium and released then .

(A) The ballon undergoes simple harmonic motion with period $2\pi \sqrt{\left(\frac{\rho_{\text{air}}}{\rho_{\text{air}} - \rho_{\text{He}}} \right) \frac{\ell}{g}}$

(B) The ballon undergoes simple harmonic motion with period $2\pi \sqrt{\left(\frac{\rho_{\text{air}} - \rho_{\text{He}}}{\rho_{\text{air}}} \right) \frac{\ell}{g}}$

(C) The ballon undergoes simple harmonic motion with period $2\pi \sqrt{\left(\frac{\rho_{\text{He}}}{\rho_{\text{air}} - \rho_{\text{He}}} \right) \frac{\ell}{g}}$

(D) The ballon undergoes conical oscillations with period $2\pi \sqrt{\left(\frac{\rho_{\text{air}} + \rho_{\text{He}}}{\rho_{\text{air}} - \rho_{\text{He}}} \right) \frac{\ell}{g}}$

Ans. [C]

Sol.

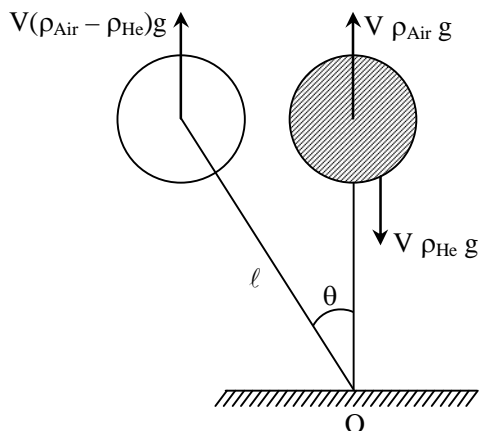

$$\tau_0 = V (\rho_{\text{Air}} - \rho_{\text{He}}) g \ell \sin \theta$$

For small angular displacement (θ)

$$\tau_0 = V (\rho_{\text{Air}} - \rho_{\text{He}}) g \ell \theta$$

$$I \alpha = V [\rho_{\text{Air}} - \rho_{\text{He}}] g \ell \theta$$

$$\rho_{\text{He}} V \ell^2 \alpha = V [\rho_{\text{Air}} - \rho_{\text{He}}] \ell \theta g$$

$$\alpha = \left[\frac{\rho_{\text{Air}} - \rho_{\text{He}}}{\rho_{\text{He}}} \right] \frac{g}{\ell} \theta$$

$$\omega = \sqrt{\left(\frac{\rho_{\text{Air}} - \rho_{\text{He}}}{\rho_{\text{He}}} \right) \frac{g}{\ell}}$$

$$= 2\pi \sqrt{\frac{\ell}{g} \frac{\rho_{\text{He}}}{(\rho_{\text{Air}} - \rho_{\text{He}})}}$$

92. Consider a cube of uniform charge density ρ . The ratio of electrostatic potential at the centre of the cube to that at one of the corners of the cube is

(A) 2 (B) $\sqrt{3}/2$ (C) $\sqrt{2}$ (D) 1

Ans. [A]

Sol.

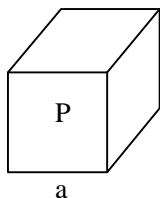
Let at the corner of cube potential = V_0

$$\text{Potential} \propto \frac{Q}{\text{Side of cube}}$$

$$Q = \rho \times a^3$$

$$\text{So potential} \propto \frac{\rho a^3}{a}$$

$$\text{Potential} \propto a^2$$

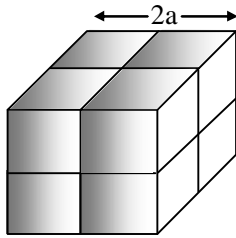

Big cube consist of 8 cube

At centre of big cube of side $2a$, potential is $8V_0$

Potential at corner of big cube = $V_0 \times (2)^2 = 4V_0$

$$\text{Required ratio} = \frac{8V_0}{4V_0} = 2 : 1$$

93. Two infinitely long wires each carrying current I along the same direction are made into the geometry as shown in the figure. The magnetic field at the point P is

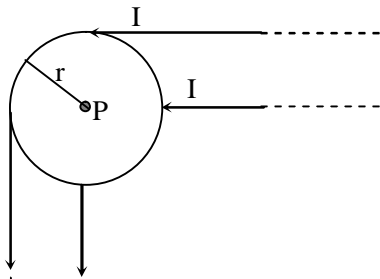

(A) $\frac{\mu_0 I}{\pi r}$

(B) $\frac{\mu_0 I}{r} \left(\frac{1}{\pi} + \frac{1}{4} \right)$

(C) Zero

(D) $\frac{\mu_0 I}{2\pi r}$

Ans. [D]
Sol.

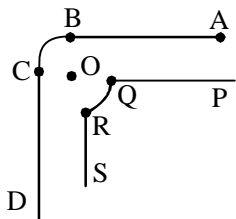

$$\begin{aligned} (\vec{B})_O &= (\vec{B})_{\text{wire AB}} + (\vec{B})_{\text{BC Arc}} \\ &+ \vec{B}_{\text{CD wire}} + (\vec{B})_{\text{PQ wire}} \\ &+ \vec{B}_{\text{QR (Arc)}} + \vec{B}_{\text{RS wire}} \\ B_{\text{PQ}} &= B_{\text{RS}} = 0 \\ \vec{B}_{\text{BC}} &= -\vec{B}_{\text{QR}} \end{aligned}$$

$$\begin{aligned} (\vec{B})_{\text{wire AB}} &= \vec{B}_{\text{CD}} \\ \vec{B}_{\text{net}} &= (\vec{B})_{\text{wire AB}} + (\vec{B})_{\text{wire CD}} \\ \Rightarrow \frac{\mu_0 I}{4\pi r} &+ \frac{\mu_0 I}{4\pi r} \\ \vec{B}_{\text{net}} &= \frac{\mu_0 I}{2\pi r} \end{aligned}$$

94. A photon of wavelength λ is absorbed by an electron confined to a box of length $\sqrt{35h\lambda/8mc}$. As a result, the electron makes a transition from state $k = 1$ to the state n . Subsequently the electron transits from the state n to the state m by emitting a photon of wavelength $\lambda' = 1.85\lambda$. Then
 (A) $n = 4; m = 2$ (B) $n = 5; m = 3$ (C) $n = 6; m = 4$ (D) $n = 3; m = 1$

Ans. [C]

Sol.

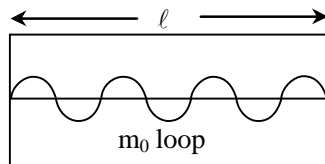

$$\text{KE of } e^- = \frac{hc}{\lambda}$$

$$\lambda_{\text{de-broglie}} = \frac{h}{\sqrt{2m\text{KE}}} = \frac{h}{\sqrt{2m \times \frac{hc}{\lambda}}} = \frac{\sqrt{h\lambda}}{\sqrt{2mc}}$$

$$\frac{m_0 \lambda_{\text{debroglie}}}{2} = \ell$$

$$\frac{m_0}{2} \times \frac{\sqrt{h\lambda}}{\sqrt{2mc}} = \frac{\sqrt{35h\lambda}}{\sqrt{8mc}} \Rightarrow \frac{m_0}{2\sqrt{2}} = \frac{\sqrt{35}}{2\sqrt{2}}$$

$$m_0 = \sqrt{35} = 5.8 \approx 6$$

i.e. e^- get excite to state 6.

$$\therefore n = 6$$

95. Consider two masses with $m_1 > m_2$ connected by a light inextensible string that passes over a pulley of radius R and moment of inertia I about its axis of rotation. The string does not slip on the pulley and the pulley turns without friction. The two masses are released from rest separated by a vertical distance $2h$. When the two masses pass each other, the speed of the masses is proportional to

(A) $\sqrt{\frac{m_1 - m_2}{m_1 + m_2 + \frac{1}{R^2}}}$

(B) $\sqrt{\frac{(m_1 + m_2)(m_1 - m_2)}{m_1 + m_2 + \frac{1}{R^2}}}$

(C) $\sqrt{\frac{m_1 + m_2 + \frac{1}{R^2}}{m_1 - m_2}}$

(D) $\sqrt{\frac{1}{m_1 + m_2}}$

Ans. [C]

Sol.

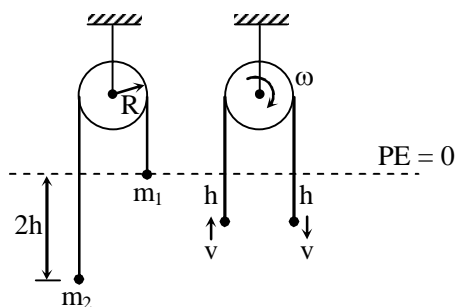

The total mechanical energy of system = conserved

Hence

$$KE_i + PE_i = KE_f + PE_f$$

$$0 - m_2g \times 2h = \frac{1}{2} m_2v^2 + \frac{1}{2} m_1v^2 + \frac{1}{2} I\omega^2 - m_1gh - m_2gh$$

$$\text{Also } \omega = \frac{v}{R}$$

$$(m_1 - m_2)gh = \frac{1}{2} (m_1 + m_2)v^2 + \frac{1}{2} I \left(\frac{v}{R} \right)^2$$

$$(m_1 - m_2)gh = \frac{v^2}{2} \left[m_1 + m_2 + \frac{I}{R^2} \right]$$

$$v \propto \sqrt{\frac{m_1 - m_2}{m_1 + m_2 + \frac{I}{R^2}}}$$

96. An ideal gas is taken reversibly around the cycle a-b-c-d-a as shown on the T (temperature) – S (entropy) diagram

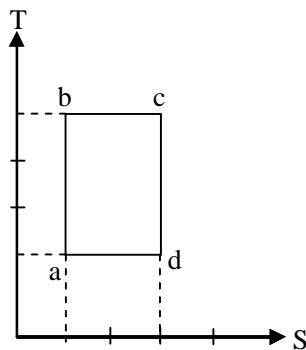

The most appropriate representation of above cycle on a U (internal energy) – V (volume) diagram is

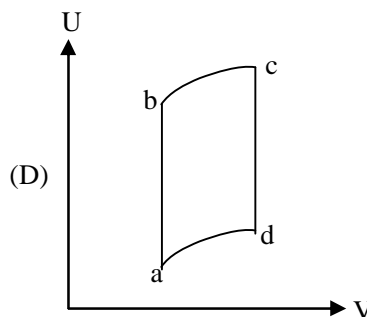
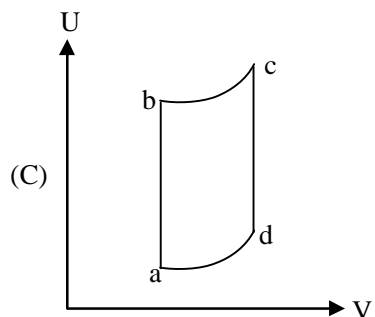
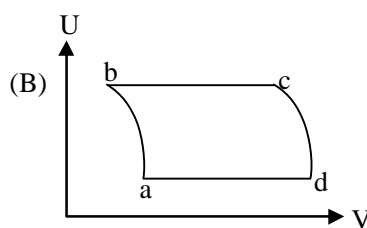
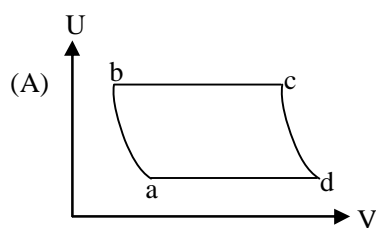

Ans. [A]

Sol.

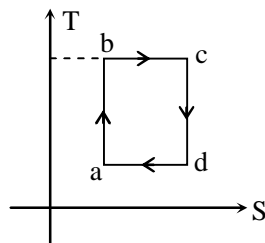
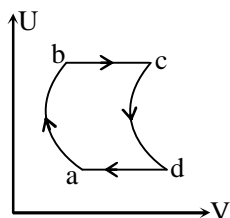
bc \Rightarrow Isothermal process so U remain constantcd \Rightarrow Isentropic process so S remain constant \therefore bc should be straight line parallel to V & cd graph should be

97. The heat capacity of one mole an ideal is found to be $C_V = 3R (1 + aRT)/2$ where a is a constant. The equation obeyed by this gas during a reversible adiabatic expansion is -

- (A) $TV^{3/2}e^{aRT} = \text{constant}$
 (B) $TV^{3/2}e^{3aRT/2} = \text{constant}$
 (C) $TV^{3/2} = \text{constant}$
 (D) $TV^{3/2}e^{2aRT/3} = \text{constant}$

Ans. [A]

Sol. Adiabatic process

$$TV^{\gamma-1} = C$$

$$\gamma = 1 + \frac{2}{f}$$

$$TV^{\frac{2}{f}} = C$$

$$C_V = \frac{fR}{2} = \frac{3R(1+aRT)}{2}$$

$$\frac{fR}{2} = \frac{3Re^{aRT}}{2}$$

$$\frac{2}{f} = \frac{2}{3e^{aRT}}$$

$$TV^{\frac{2}{3e^{aRT}}} = C$$

$$TV^{\frac{3}{2}} = C$$

Ans. given is $TV^{\frac{3}{2}}e^{aRT}$

So no option is matching may be due to printing mistake.

98. If the input voltage V_i to the circuit below is given by $V_i(t) = A \cos(2\pi ft)$, the output voltage is given by $V_o(t) = B \cos(2\pi ft + \phi)$ -

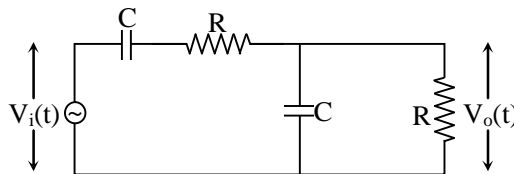

Which one of the following four graphs best depict the variation of ϕ vs f ?

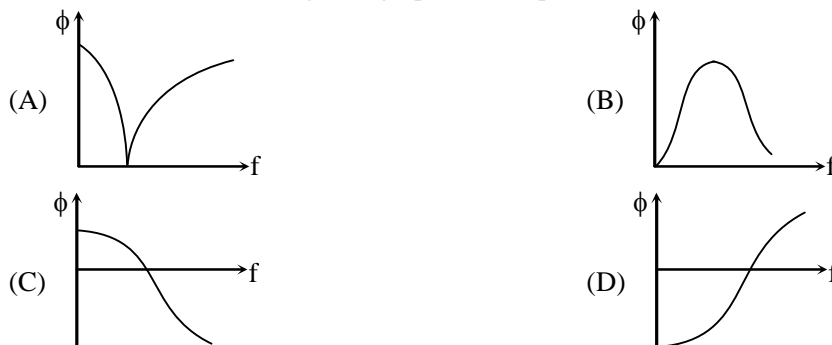

Ans. [C]
Sol.

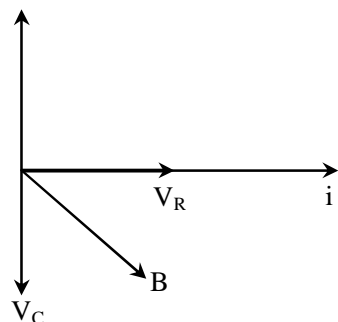

Resultant of V_C , V_R & B give V_i and angle between V_i & B is ϕ . When f is very high $X_C \rightarrow 0$ then $V_C \rightarrow 0 \therefore$ Resultant of V_C , V_R & B lie between B and V_R .

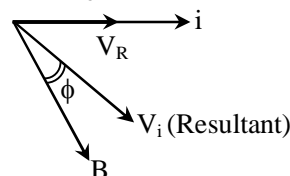

B lag behind ϕ
 \therefore At higher frequency ϕ become - ve.

99. A glass prism has a right-triangular cross section ABC , with $\angle A = 90^\circ$. A ray of light parallel to the hypotenuse BC and incident on the side AB emerges grazing the side AC . Another ray, again parallel to the hypotenuse BC , incident on the side AC suffers total internal reflection at the side AB . Which one of the following must be true about the refractive index μ of the material of the prism ?

- (A) $\sqrt{\frac{3}{2}} < \mu < \sqrt{2}$ (B) $\mu > \sqrt{3}$
(C) $\mu < \sqrt{\frac{3}{2}}$ (D) $\sqrt{2} < \mu < \sqrt{3}$

Ans. [A]

Sol.

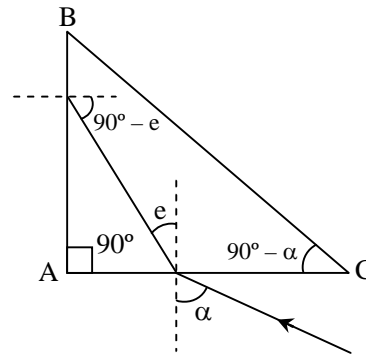
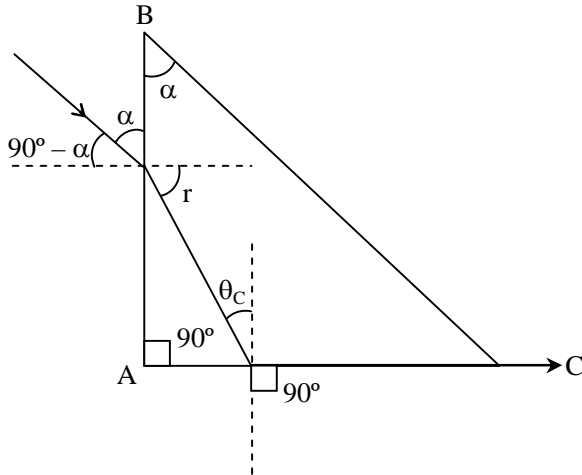

$$r + \theta_C = 90^\circ \quad \dots(1)$$

$$1 \times \sin(90^\circ - \alpha) = \mu \sin r \quad \dots(2)$$

$$\cos \alpha = \mu \sin r \quad \dots(3)$$

$$90^\circ - e > \theta_C \quad \dots(4)$$

$$\mu \sin e = 1 \times \sin \alpha \quad \dots(5)$$

$$(3) \text{ \& } (4)$$

$$90^\circ - \theta_C > e$$

$$\cos \theta_C > \sin e$$

$$\cos \theta_C > \frac{\sin \alpha}{\mu}$$

$$1 - \sin^2 \theta_C > \frac{1}{\mu^2} [1 - \mu^2 \sin^2 r]$$

$$1 - \frac{1}{\mu^2} > \frac{1}{\mu^2} [1 - \mu^2 \sin^2(90^\circ - \theta_C)]$$

$$1 - \frac{1}{\mu^2} > \frac{1}{\mu^2} - \cos^2 \theta_C$$

$$1 - \frac{2}{\mu^2} > - \left[1 - \frac{1}{\mu^2} \right]$$

$$2 > \frac{3}{\mu^2}$$

$$\mu > \sqrt{\frac{3}{2}}$$

$$(1) \text{ \& } (2)$$

$$\cos \alpha = \mu \sin(90^\circ - \theta_C)$$

$$\cos \alpha = \mu \cos \theta_C$$

$$\cos \alpha < 1$$

$$\mu \cos \theta_C < 1$$

$$\sqrt{1 - \frac{1}{\mu^2}} < \frac{1}{\mu}$$

$$1 - \frac{1}{\mu^2} < \frac{1}{\mu^2}$$

$$1 < \frac{2}{\mu^2}$$

$$\mu < \sqrt{2}$$

$$\therefore \sqrt{\frac{3}{2}} < \mu < \sqrt{2}$$

100. A smaller cube with side b (depicted by dashed lines) is excised from a bigger uniform cube with side a as shown below such that both cubes have a common vertex P . Let $X = a/b$. If the centre of mass of the remaining solid is at the vertex O of smaller cube then X satisfies.

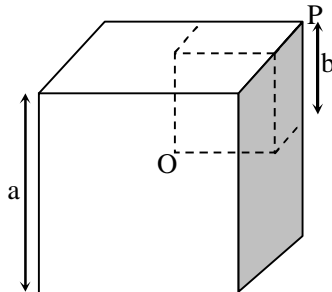

(A) $X^3 - X^2 - X - 1 = 0$

(C) $X^3 + X^2 - X - 1 = 0$

(B) $X^2 - X - 1 = 0$

(D) $X^3 - X^2 - X + 1 = 0$

Ans.

[A]

Sol.

Centre of mass of remaining cube x coordinate = b

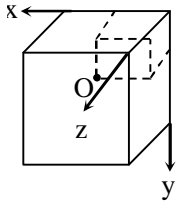

$$X_{CM} = \frac{\rho a^3 \times \frac{a}{2} - \rho b^3 \times \frac{b}{2}}{\rho a^3 - \rho b^3}$$

We will consider removed mass as a negative mass

$$b = \frac{\frac{\rho a^4}{2} - \frac{\rho b^4}{2}}{\rho a^3 - \rho b^3}$$

$$a^3 b - b^4 = \frac{a^4}{2} - \frac{b^4}{2}$$

$$2a^3 b - 2b^4 = a^4 - b^4$$

$$\text{put } a = bx \Rightarrow 2b^4 x^3 b - 2b^4 = b^4 x^4 - b^4$$

$$2x^3 - 1 = x^4$$

$$2x^3 - 2 + 1 = x^4$$

$$2[x^3 - 1] = (x^2 - 1)(x^2 + 1)$$

$$2[x - 1][x^2 + 1 + x] = [x - 1][x + 1][x^2 + 1]$$

$$2x^2 + 2 + 2x = x^3 + x + x^2 + 1$$

$$x^3 - x^2 - x - 1 = 0$$

CHEMISTRY

101. X, Y and Z in the following reaction sequence are

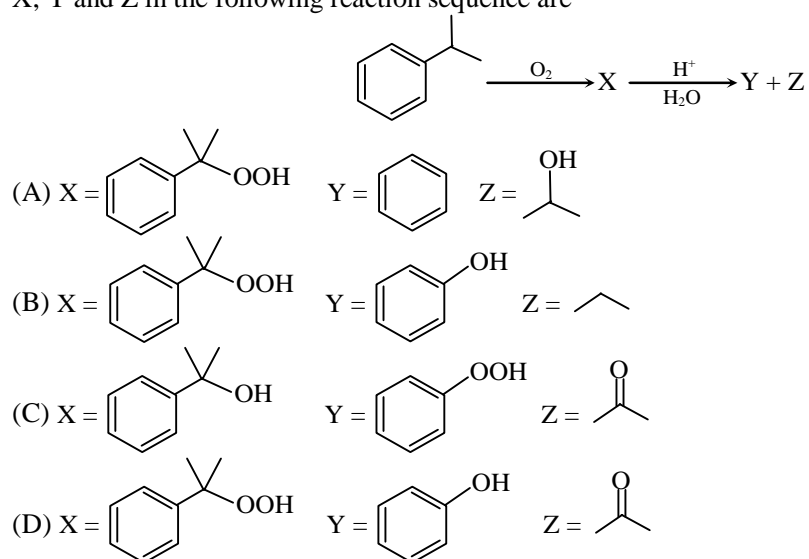

Ans. [D]
Sol.

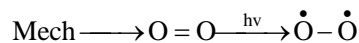
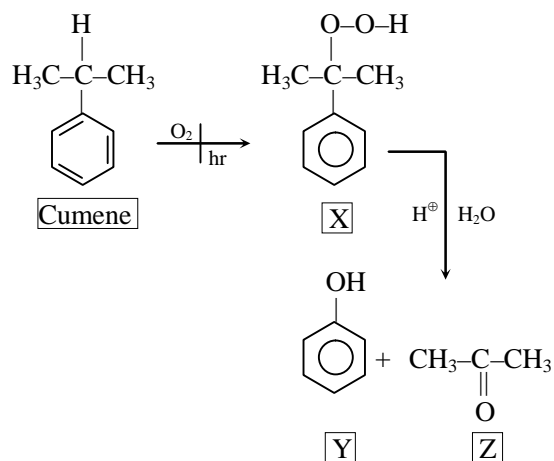

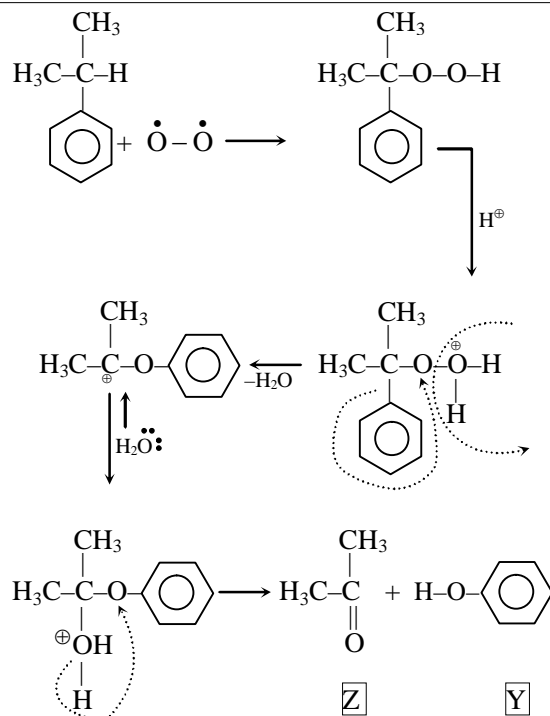

102. The reagent required for the following two step transformation are

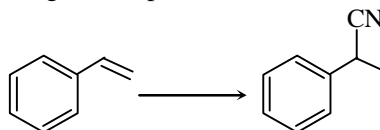

- (A) (i) HBr, benzoyl peroxide ; (ii) CH_3CN
 (B) (i) HBr, (ii) NaCN
 (C) (i) Br_2 , (ii) NaCN
 (D) (i) NaBr, (ii) NaCN

Ans. [B]

Sol.

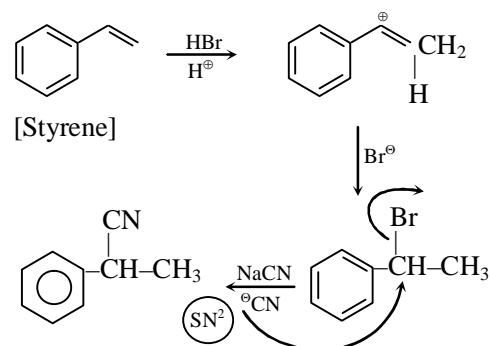

103. In the reaction sequence

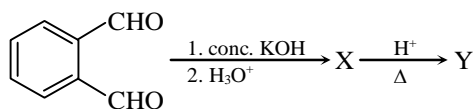

The major product X and Y, respectively, are

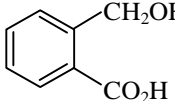
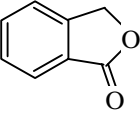
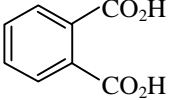
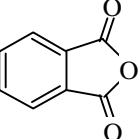
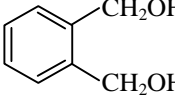
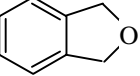
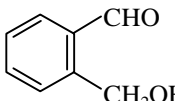
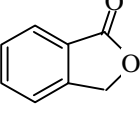
- (A)  and 
- (B)  and 
- (C)  and 
- (D)  and 

Ans. [A]

Sol.

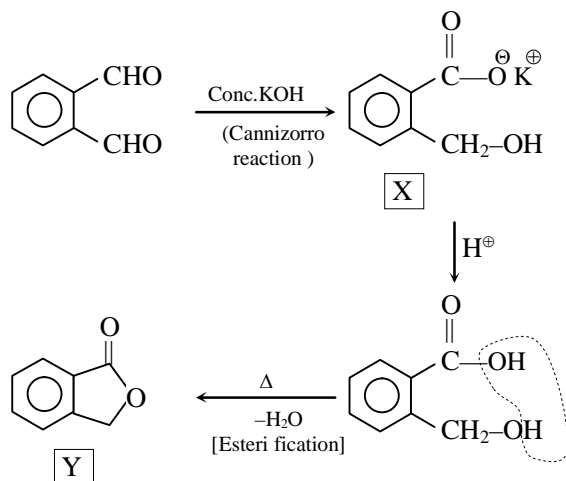

104. In the following reactions

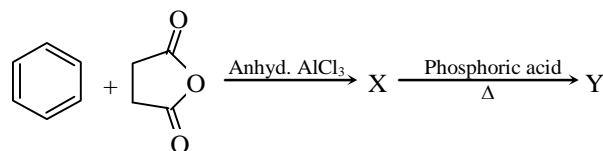

X and Y, respectively, are

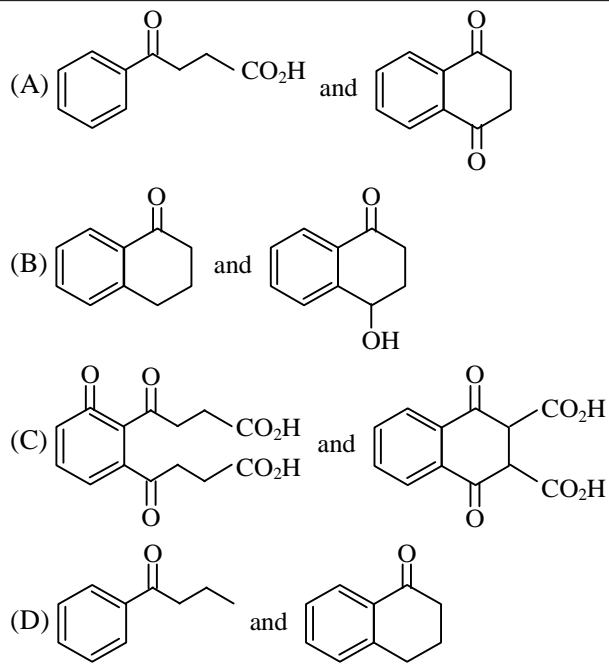

Ans. [A]

Sol.

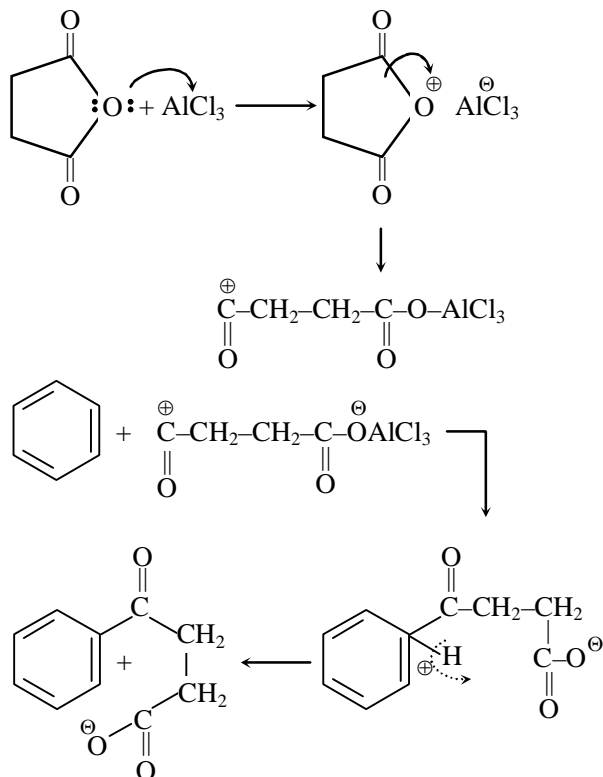

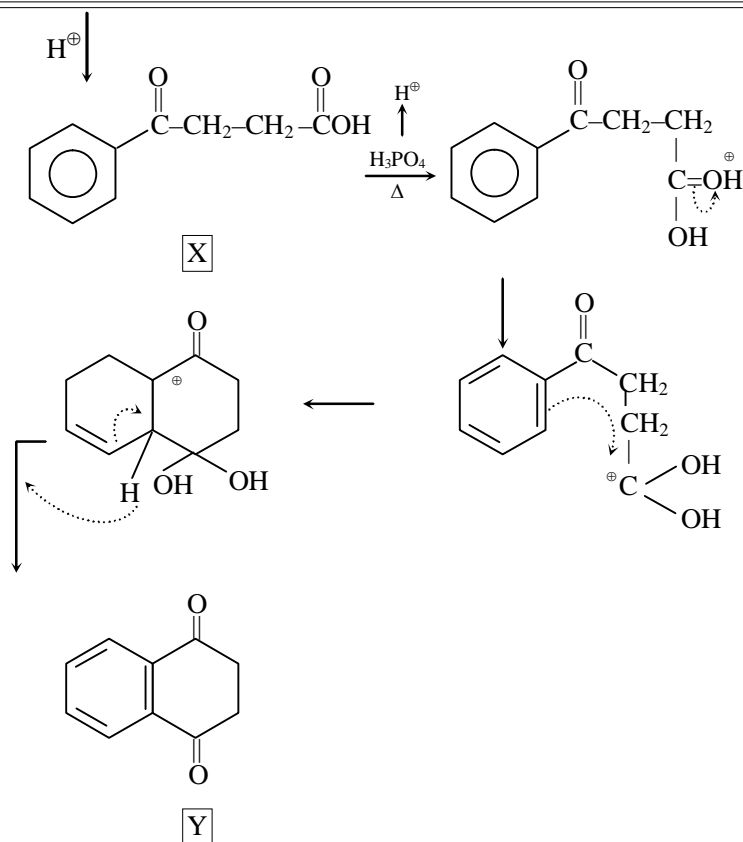

105. Copper (atomic mass = 63.5) crystallizes in a FCC lattice and has density 8.93 g.cm^{-3} .

The radius of copper atom is closest to

- (A) 361.6 pm (B) 511.4 pm (C) 127.8 pm (D) 102.8 pm

Ans. [C]

Sol.
$$d = \frac{N \times M}{N_A \times a^3}$$

$$8.93 = \frac{4 \times 63.5}{6.023 \times 10^{23} \times a^3}$$

$$a^3 = 4.72 \times 10^{-23}$$

$$a = (47.2 \times 10^{-24})^{1/3}$$

$$= 3.61 \times 10^{-8} \text{ cm}$$

$$= 3.61 \times 10^{-10} \text{ m}$$

$$= 361 \text{ pm}$$

force

$$a = 2\sqrt{2} r$$

$$r = \frac{a}{2\sqrt{2}} = 127.8$$

106. Given the standard potentials $E^\circ(\text{Cu}^{2+}/\text{Cu})$ and $E^\circ(\text{Cu}^+/\text{Cu})$ as 0.340 V and 0.522 V respectively, the value of $E^\circ(\text{Cu}^{2+}/\text{Cu}^+)$ is

- (A) 0.364 V (B) 0.158 V (C) -0.182 V (D) -0.316 V

Ans. [B]

Sol.

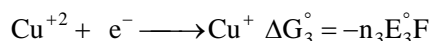
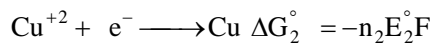
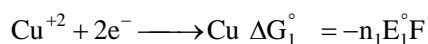

$$\Delta G_3^{\circ} = \Delta G_1^{\circ} - \Delta G_2^{\circ}$$

$$-n_3 E_3^{\circ} F = -n_1 E_1^{\circ} F + n_2 E_2^{\circ} F$$

$$E_3^{\circ} = \frac{n_1 E_1^{\circ} - n_2 E_2^{\circ}}{n_3} = \frac{2 \times 0.34 - .522}{1} = .158 \text{ V}$$

107. For electroplating, 1.5 amp current is passed for 250 s through 250 mL of 0.15 M solution of MSO_4 . Only 85% of the current was utilized for electrolysis. The molarity of MSO_4 solution after electrolysis is closest to [Assume that the volume of the solution remained constant]

(A) 0.14 (B) 0.014 (C) 0.07 (D) 0.035

Ans. [A]

Sol. No. of mole = $\frac{i \times t}{96500 \times v.f}$, $n \times v.f = \frac{i \times t}{96500} \times n = \frac{1.5 \times 250}{96500 \times 2} \times 0.85$

$$n = .00165 \text{ (deposited)}$$

$$n_i = \frac{250 \times .15}{1000} = .0375 \text{ (initial mole)}$$

$$n_{\text{left}} = .03585 \text{ (mole left)}$$

$$M_{\text{left}} = \frac{.03585}{.25} = 0.143$$

108. The hybridization of the central atom and the shape of $[\text{IO}_2\text{F}_3]^{2-}$ ion respectively, are -

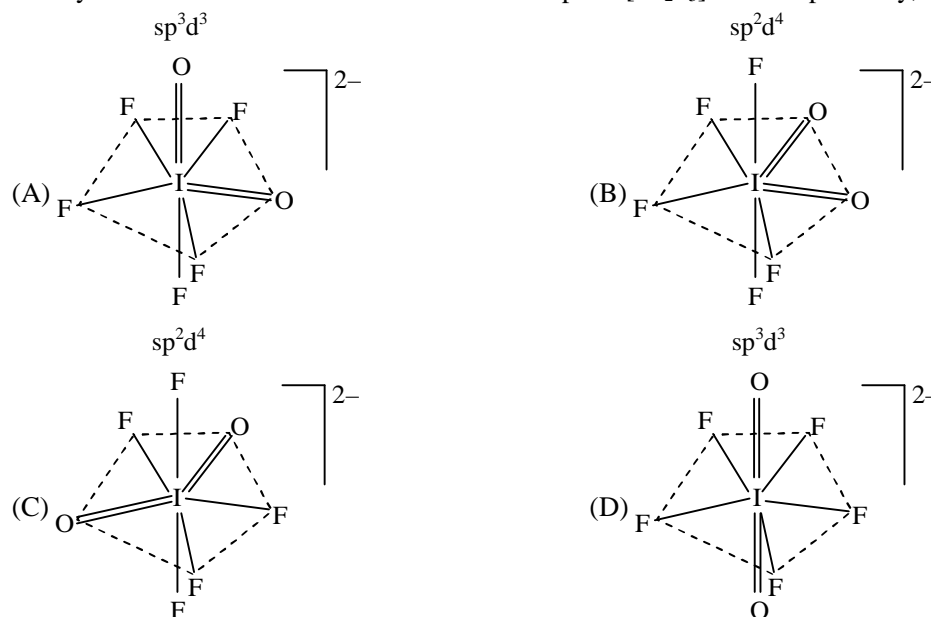

Ans. [D]

Sol. $[\text{IO}_2\text{F}_5]^{2-}$ ion

Hybridisation is sp^3d^3 shape is pentagonal bipyramidal

Double bond cause more repulsion so they would be on Axial position 180° angle to each other so shape is

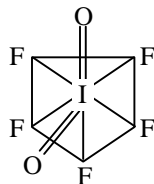

109. 2.33 g of compound X (empirical formula $\text{CoH}_{12}\text{N}_4\text{Cl}_3$) upon treatment with excess AgNO_3 solution produces 1.435 g of a white precipitate. The primary and secondary valences of cobalt in compound X, respectively, are

[Given : Atomic mass : Co = 59, Cl = 35.5, Ag = 108]

(A) 3, 6

(B) 3, 4

(C) 2, 4

(D) 4, 3

Ans. [A]

Sol. M.wt = $59 + 12 + 14 \times 4 + 35.5 \times 3 = 233.5$

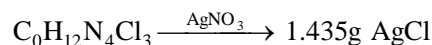

$$\frac{2.33}{233.5}\text{g} = 0.01 \text{ mole} \quad (0.01 \text{ mole})$$

(i) 0.01 mole molecule produce 0.01 mole AgCl

\therefore one replaceable Cl^\ominus ion

so formula of complex is

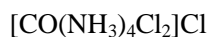

(ii) Oxidation no. of Co is +3 so primary valency is 3.

(iii) Coordination no. is 6 so sec. valency is 6

so ans. is 3,6

110. The specific conductance (κ) of 0.02 M aqueous acetic acid solution at 298 K is $1.65 \times 10^{-4} \text{ S cm}^{-1}$. The degree of dissociation of acetic acid is

[Given : equivalent conductance at infinite dilution of $\text{H}^+ = 349.1 \text{ S cm}^2 \text{ mol}^{-1}$ and $\text{CH}_3\text{COO}^- = 40.9 \text{ S cm}^2 \text{ mol}^{-1}$]

(A) 0.021

(B) 0.21

(C) 0.012

(D) 0.12

Ans. [A]

Sol. $\lambda_M = \frac{1000 \times \kappa}{M}$

$$= \frac{1000 \times 1.65 \times 10^{-4}}{0.02}$$

$$= 8.25$$

$$\lambda_H^\infty = \lambda_M^\infty(\text{H}^+) + \lambda_M^\infty(\text{CH}_3\text{COO}^-)$$

$$= 349.1 + 40.9$$

$$= 390$$

$$\alpha = \frac{8.25}{390} = .0211$$

BIOLOGY

111. Match the following organelles in Group I with the structures in Group II. Choose the correct combination.

Group I

P. Mitochondrion

Q. Golgi

R. Chloroplast

S. Centrosome

(A) P-ii, Q-i, R-iii, S-iv

(C) P-iv, Q-i, R-ii, S-iii

Group II

i. Cisternae

ii. Cristae

iii. Thylakoids

iv. Radial spokes

(B) P-iii, Q-i, R-ii, S-iv

(D) P-iv, Q-ii, R-i, S-iii

Ans. [A]

Sol. Cristae are invaginations of inner mitochondrial membrane. Cisternae is unit of golgi body where glycosidation and glycosylation takes place. Grana of chloroplast are composed of thylakoids. Centrosome contains centrioles with radial spokes.

112. A human population containing 200 individuals has two alleles at the 'T' locus, named T and t . T , which produces tall individuals, is dominant over t , which produces short individuals. If the population has 90 TT , 40 Tt and 70 tt genotypes, what will be the frequencies of these two alleles in this population ?

(A) T , 0.50 ; t , 0.50

(B) T , 0.55 ; t , 0.45

(C) T , 0.45 ; t , 0.35

(D) T , 0.90 ; t , 0.10

Ans. [B]

Sol. A population with 200 individual has 90 TT , 40 Tt and 70 tt genotypes

i.e. dominant allele (T) is $TT + Tt$

$$\text{i.e. } 90 + 90 + 40$$

$$\Rightarrow 220$$

Recessive allele (t) is $Tt + tt$

$$\text{i.e. } 40 + 70 + 70$$

$$\Rightarrow 180$$

Total allele = 400

$$\text{Dominant allele (T) frequency} = \frac{220}{400} = 0.55$$

$$\text{Recessive allele (t) frequency} = \frac{180}{400} = 0.45$$

113. Which of the following graphs best describes the oxygen dissociation curve where pO_2 is the partial pressure of oxygen ?

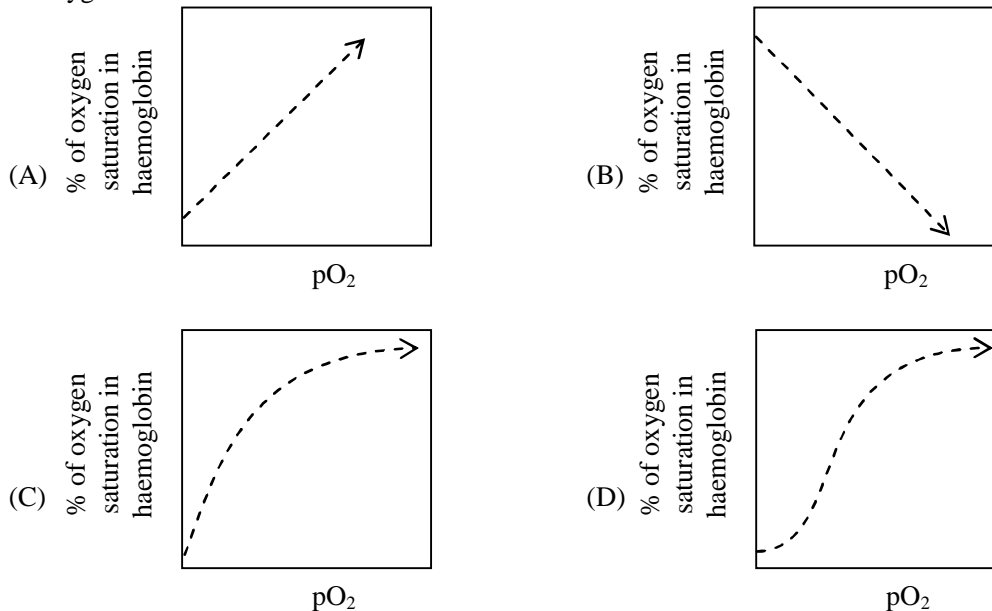

Ans. [D]

Sol. Oxyhaemoglobin dissociation curve is sigmoid shaped.

114. Which of the following best describes the DNA content and the number of chromosomes at the end of S and M phases of the cell cycle in mitosis, if the DNA content of the cell in the beginning of cell cycle (G₁ phase) is considered as C and the number of chromosomes 2N ?

- (A) 2C and 2N for S phase ; 2C and 2N for M phase
 (B) 2C and N for S phase ; 2C and N for M phase
 (C) 2C and 2N for S phase ; C and 2N for M phase
 (D) C and N for S phase ; C and 2N for M phase

Ans. [C]

Sol.

	G ₁	→	S	→	G ₂	→	M
DNA Content	C		2C		2C		2C → C
No. of Chromosome	2N		2N		2N		2N → 4N → 2N

115. Study the following graph of metabolic rate of various terrestrial mammals as a function of their body mass and choose the correct option below.

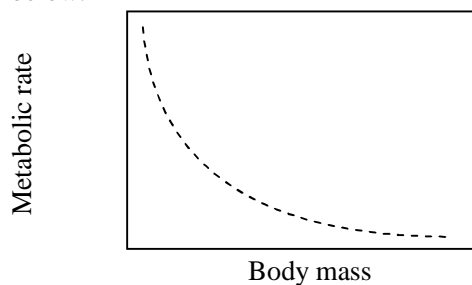

- (A) Animals are distributed throughout the curve with the smaller animals towards the left and progressively bigger animals towards the right
- (B) The smaller animals below a certain critical mass cluster at the left end of the curve and the larger animals above the critical mass cluster on the right end
- (C) Animals are distributed throughout the curve with the larger animals towards the left and progressively smaller animals towards the right
- (D) The larger animals above a certain critical mass cluster at the left end of the curve and the smaller animals below the critical mass cluster on the right end

Ans. [A]

Sol. The metabolic theory of Ecology (MTE) is an extension of Kleiber's law and states that the metabolic rate of organism is the fundamental biological rate that governs most observed patterns in ecology

- 116.** Match the human disorders shown in Group I with the biochemical processes in Group II. Choose the correct combination

Group I

- P. Phenylketonuria
Q. Albinism
R. Homocystinuria
S. Argininemia

Group II

- i. Melanin synthesis
ii. Conversion of Phenylalanine to Tyrosine
iii. Tyrosine degradation
iv. Methionine metabolism
v. Urea Synthesis
- (A) P-ii, Q-i, R-iv, S-v
(B) P-i, Q-iv, R-ii, S-v
(C) P-ii, Q-i, R-v, S-iii
(D) P-v, Q-iii, R-i, S-ii

Ans. [A]

Sol. Phenylketonuria is due to non-conversion of phenylalanine into tyrosine. Albinism is non-synthesis of melanin pigment. Homocystinuria is associated with methionine metabolism. Argininemia is associated with urea synthesis.

- 117.** An mRNA is transcribed from a DNA segment having the base sequence 3'-TACATGGGTCCG-5'. What will be the correct order of binding of the four amino acyl-tRNA complexes given below during translation of this mRNA ?

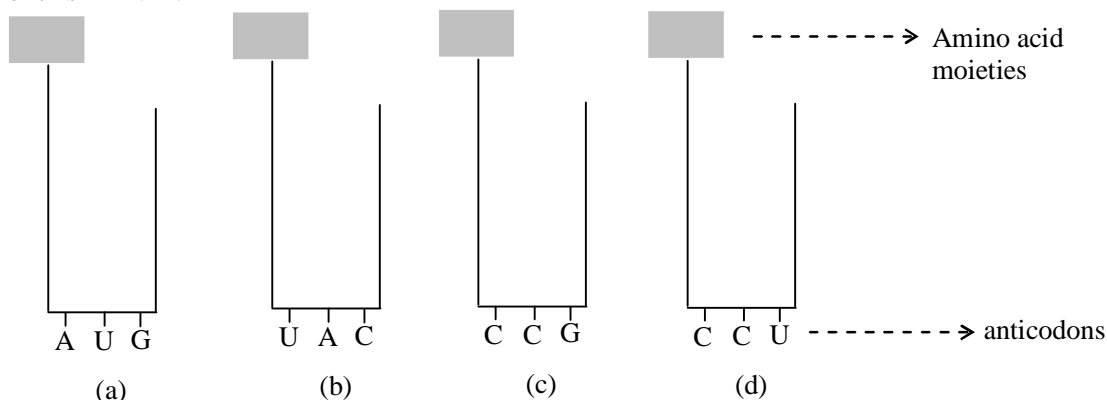

- (A) a, b, c, d
(B) b, a, c, d
(C) c, d, a, b
(D) b, a, d, c

Ans. [Bonus]

Sol. DNA sequence 3' TAC ATG GGT CCG 5'
mRNA 5' AUG UAC CCA GGC 3'

t-RNA

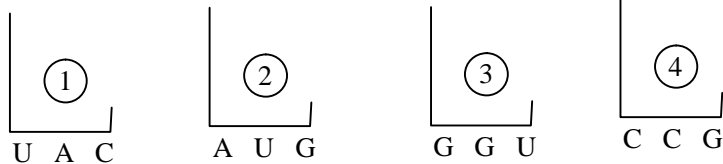

mRNA 5' A U G U A C C C A G G C 3'

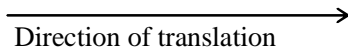

None of the option is correct

As option (D) diagram is incorrect

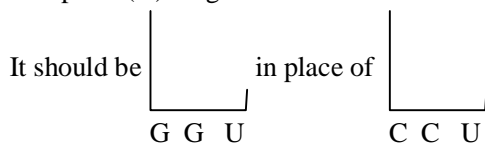

- 118.** If the initial number of template DNA molecules in a PCR reaction is 1000, the number of product DNA molecules at the end of 20 cycles will be closest to
(A) 10^3 (B) 10^6 (C) 10^9 (D) 10^{12}

Ans. [C]

Sol. During PCR, the number of DNA molecules increases by 2^n . Where 'n' is number of divisions

- 119.** The allele for black hair (B) is dominant over brown hair (b) and the allele for brown eye (E) is dominant over blue eye (e). Out of the offsprings obtained upon mating a black-haired and brown-eyed individual (BbEe) with a brown-haired and brown-eyed individual (bbEE), the ratio of brown-haired and brown-eyed individuals to black-haired and brown-eyed individuals is
(A) 2 : 1 (B) 3 : 1
(C) 1 : 1 (D) 1 : 2

Ans. [C]

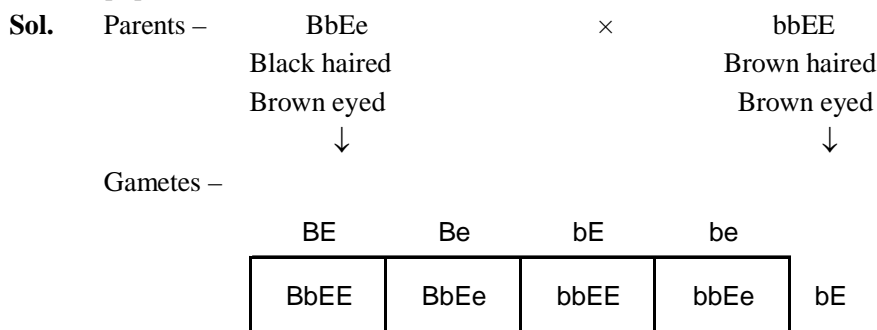

Ratio of Brown haired and Brown eyed to Black haired and Brown eyed is 2 : 2 or 1 : 1

120. In an experiment represented in the schematic below, a plant species was grown in different day and night cycles and its photoperiodic flowering behaviour was noted. This species is a

Light	Dark	Flowering
16 hrs	6 hrs	No flower
16 hrs	7 hrs	No flower
16 hrs	8 hrs	No flower
16 hrs	9 hrs	Flower
16 hrs	10 hrs	Flower
16 hrs	11 hrs	Flower
8 hrs	10 hrs	Flower
10 hrs	10 hrs	Flower
12 hrs	10 hrs	Flower
8 hrs	8 hrs	No Flower
10 hrs	8 hrs	No Flower
12 hrs	8 hrs	No Flower

- (A) short day plant and actually measures day length to flower
 (B) short day plant and actually measures night length to flower
 (C) long day plant and actually measures night length to flower
 (D) long day plant and actually measures day length to flower

Ans. [B]

Sol. SDP (Short day plants) or LNP (Long Night Plants) flowers only when photoperiod is below critical day length (Critical photoperiod) or they are responsive to night length and flower when night length is above critical dark period.

In this experiment plant flowers when dark period is above 8 hrs.

So, it is SDP and actually measures night length to flower.